

Carl Friedrich  
Christian Fasch  
Missa a 16 voci

---

herausgegeben von / edited by  
Ryan Michael Kelly

Partitur/Full score

# Inhalt

Vorwort / Foreword		III
Faksimileabbildungen		IX
1. Kyrie eleison	Coro I–IV	1
2. Christe eleison	Coro I–IV	8
3. Kyrie eleison	Coro I–IV	13
4. Gloria in excelsis Deo	Soprano I, II, III	20
5. Et in terra pax	Coro I–IV	20
6. Laudamus te	Soprano concertato, Coro I–IV	35
7. Gratias agimus tibi	Tenore principale, Coro I, II–IV	51
8. Domine Deus	Coro II–IV	58
9. Quoniam tu solus Sanctus	SSATTB	71
10. Cum Sancto Spiritu	Coro I–IV	77
Critical Report		99

Zu diesem Werk ist folgendes Aufführungsmaterial erhältlich:

Partitur (Carus 27.083), zwei Chorpartituren (Carus 27.083/05: Coro I+IV, mit Soli; Carus 27.083/06: Coro II+III), Organo (Carus 27.083/49).

Eine CD-Einspielung mit dem Kammerchor Stuttgart unter der Leitung von Frieder Bernius (Carus 83.222) liegt vor.

The following performance material is available:

full score (Carus 27.083), two choral scores (Carus 27.083/05: Coro I+IV, with soloists; Carus 27.083/06: Coro II+III), organ (Carus 27.083/49).

A CD recording by the Kammerchor Stuttgart under the direction of Frieder Bernius (Carus 83.222) is also available.

## Vorwort

### Carl Faschs Biografie

Carl Friedrich Christian Fasch wurde am 18. November 1736 in Zerbst geboren. Zunächst studierte er Musik bei seinem Vater, dem bekannten Zerbster Kapellmeister Johann Friedrich Fasch. Wie man Fugen komponiert, brachte er sich selbst bei. 1750 ging er für drei Jahre von zuhause fort, um Violine, Cembalo und Orgel bei Johann Christian Hertel und Carl Höckh zu studieren.<sup>1</sup> Während des Studiums erregte er mit seinen guten Fertigkeiten auf dem Tasteninstrument die Aufmerksamkeit von Franz Benda, dem Konzertmeister Friedrichs des Großen. Auf Empfehlung Bendas bot der König Fasch eine Anstellung als zweiter Hof-Cembalist an. Fasch nahm diese 1756 an und blieb bis zu seinem Tod 1800 in königlichen Diensten.

Obwohl charismatisch, herzlich lachend und mit einem trockenen Humor, war er gleichzeitig sehr schüchtern und hatte wenig Freunde. Er heiratete nicht und hatte keine Kinder. Sein engster Freund war Carl Zelter, der 1784–86 Unterricht bei Fasch nahm und sich in seinen späteren Jahren um ihn kümmerte.<sup>2</sup> Faschs pianistische Fertigkeiten und seine Musikalität waren hoch angesehen, besonders die Art wie er Solisten begleitete und zu guten Aufführungen anspornte, indem er sich rasch ihrer Spielweise anpasste.<sup>3</sup> Auch für sein ungewöhnlich kultiviertes Dirigat von großen Sängerguppen wurde er gelobt.<sup>4</sup>

Da er neben C. P. E. Bach als zweiter Cembalist angestellt war und nicht zu komponieren hatte, waren Faschs höfische Verpflichtungen gering. Er hatte nie genug Verantwortung, um sich mit seinen Fähigkeiten hervortun zu können. Schon bald begleitete er das tägliche Flötenspiel des Königs und kurzzeitig war er als Interimsdirektor der Hofoper tätig.<sup>5</sup> Aber Friedrichs Zeit und Ressourcen wurden zu großen Teilen vom Krieg eingenommen, weshalb Fasch wenig zu tun hatte und ihm kaum Geld zum Leben blieb. Er stockte sein Gehalt auf indem er Schülern privaten Kompositions-, Gesangs- und Cembalo-Unterricht erteilte. Diese Unterrichtsstunden legten möglicherweise den Grundstein für seine größte berufliche Leistung: die Gründung der Sing-Akademie zu Berlin.

Im Jahr 1790 begannen zwei oder drei Musikliebhaber, sich im Haus der Charlotte Dietrich, einer von Faschs Gesangsschülerinnen, zu treffen um miteinander zu singen.<sup>6</sup> Bis Jahresmitte wuchs die Gruppe auf 12 oder 16 Sänger an, die sich andernorts regelmäßig trafen, um vier-, fünf- oder sechsstimmige Stücke von Fasch unter seiner Anleitung zu singen.<sup>7</sup> Offiziell formierten sich die Sänger 1791 als Ensemble und nannten sich ab 1793 Sing-Akademie zu Berlin. Ihre erste Aufführung fand 1792 in der Marienkirche in Berlin statt. Die Sänger erregten sofort Aufmerksamkeit, nicht nur wegen ihres schönen Klangs, sondern auch weil dies der erste gemischte Chor war, der in einer Berliner Kirche oder vielleicht sogar in ganz Deutschland auftrat.<sup>8</sup> Fasch dirigierte das Ensemble bis 1797.<sup>9</sup> Die Mitglieder sangen ausschließlich geistliche Musik, und zwar zunächst nur Musik die von Fasch komponiert war. 1794 begannen sie, auch Werke von Allegri, J. S. Bach, Graun, Händel, Mozart und anderen zu proben. Fasch, der seit Jugendjahren an komplexe, mehrstimmige Kirchenmusik herangeführt worden war, hatte sich vorgestellt, dass die Sing-Akademie die geistliche Chormusik voranbringen würde.<sup>10</sup> Das größer werdende Ensemble hatte im Jahr 1797 bereits 100 Sänger und war aus Dilettanten

und professionellen Sängern zusammengesetzt. Die Sing-Akademie wurde als bester Chor in Deutschland bezeichnet und besonders für ihre feine Intonation und die unübertroffenen Aufführungen von Werken J. S. Bachs und Händels gerühmt.<sup>11</sup>

Obwohl Fasch offiziell bis zu seinem Tod künstlerischer Leiter der Sing-Akademie blieb, übergab er 1797 aufgrund einer schweren Erkrankung die Leitung der Proben an Zelter. Fasch starb am 3. August 1800 und wurde am 7. August in Berlin auf dem Jerusalemer Friedhof am Halleschen Tor begraben. Am 8. Oktober führte die Sing-Akademie Mozarts Requiem in Erinnerung an ihren verstorbenen Leiter auf und nutzte den Erlös des Konzerts, um einen Fond zu gründen, der jährlich eine bedürftige Familie unterstützte.<sup>12</sup> Zelter verfasste 1801 eine Biografie über Fasch, und zusammen mit dem Berliner Musikalienhändler Traugott Trautwein veröffentlichte die Sing-Akademie Ende der 1830er-Jahre Faschs „Sämtliche Werke“.<sup>13</sup>

<sup>1</sup> Stephan Blaut und Susanne Oschmann, Artikel „Fasch, Carl Friedrich Christian“, in: Ludwig Finscher (Hrsg.), *Die Musik in Geschichte und Gegenwart*, Personenteil Bd. 6, Kassel 2002, Sp. 775.

<sup>2</sup> Hans-Günter Ottenberg, Artikel „Zelter, Carl Friedrich“, in: *Grove Music Online. Oxford Music Online* <Zugriff 1. September 2013>.

<sup>3</sup> Charles Burney, *An Eighteenth-Century Musical Tour in Central Europe and The Netherlands*, London 1775 (Reprint: London 1959), S. 204; Gottfried Eberle, *200 Jahre Sing-Akademie zu Berlin: Ein Kunstverein für die heilige Musik*, Berlin 1991, S. 23; Carl Friedrich Zelter, *Karl Friedrich Christian Fasch*, Berlin 1801, S. 46.

<sup>4</sup> Zelter (wie Anm. 3), S. 30–31 und Georg Schünemann, *Die Singakademie zu Berlin*, Regensburg 1941, S. 20.

<sup>5</sup> Adolf Bernhard Marx, Artikel „Fasch, Carl Friedrich Christian“, in: Gustav Schilling (Hrsg.), *Encyclopädie der gesammten musikalischen Wissenschaften, oder Universal-Lexicon der Tonkunst*, Bd. 2, Stuttgart 1835, S. 660.

<sup>6</sup> Marx (wie Anm. 5), S. 662; Eberle (wie Anm. 3), S. 26; Zelter (wie Anm. 3), S. 29.

<sup>7</sup> Heinrich Lichtenstein, *Zur Geschichte der Sing-Akademie in Berlin: Nebst einer Nachricht über das Fest am fünfzigsten Jahrestage ihrer Stiftung und einem alphabetischen Verzeichnis aller Personen, die ihr als Mitglieder angehört haben*, Berlin 1843), S. V; Beverly Jerold, „Fasch and the Beginning of Modern Artistic Choral Singing“, in: *Bach: the Journal of the Riemenschneider Bach Institute, Baldwin-Wallace College* 35 (2004), S. 75.

<sup>8</sup> Dietmar Hiller, „Karl Friedrich Fasch und die Gründung der Berliner Singakademie“, in: *Karl Friedrich Christian Fasch (1736–1800). Bericht über die wissenschaftliche Konferenz in Zerbst am 16. und 17. April 1988 aus Anlaß des 300. Geburtstages von Johann Friedrich Fasch (1688–1758)* (= Studien zur Aufführungspraxis und Interpretation der Musik des 18. Jahrhunderts, 41), Michaelstein/Blankenburg 1989, S. 16 und Ingeborg Allihn, „Öffentliche Schauspiele und Lustbarkeiten: Das Berliner Musikleben in der zweiten Hälfte des 18. Jahrhunderts“, in: *Carl Friedrich Christian Fasch (1736–1800) und das Berliner Musikleben seiner Zeit* (= Fasch-Studien, 7), Dessau 1999, S. 148.

<sup>9</sup> Ernst Ludwig Gerber, Artikel „Fasch (Carl Friedrich Christian)“, in: *Neues historisch-biographisches Lexikon der Tonkünstler*, Bd. 2, Leipzig 1812 (Reprint: Graz 1966), S. 83–84.

<sup>10</sup> Marx (wie Anm. 5), S. 660 und Zelter (wie Anm. 3), S. 32.

<sup>11</sup> „The Choral Societies of Berlin“, in: *The Musical Times and Singing Class Circular* 37 (1896), S. 318; Roderich Fuhrmann, „Carl Friedrich Christian Fasch: Ein Komponist zwischen Rokoko und Historismus (1736–1800)“, in: *Fasch und die Musik im Europa des 18. Jahrhunderts* (= Fasch-Studien, 4), Weimar 1995, S. 155; Eberle (wie Anm. 3), S. 32; Jerold (wie Anm. 7), S. 79.

<sup>12</sup> Fuhrmann (wie Anm. 11), S. 160 und Zelter (wie Anm. 3), S. 35.

<sup>13</sup> *Sämtliche Werke von Karl Christian Friedrich Fasch*, Bd. 1–7, Berliner Sing-Akademie (Hrsg.), Berlin: Trautwein, ca. 1837–39.

## Über die Messe für 16 Stimmen

Der mit Fasch befreundete Hofmusiker Johann Friedrich Reichardt besuchte 1783 Italien. Er brachte eine Abschrift der 16-stimmigen Messe von Orazio Benevoli mit und schenkte ihm diese.<sup>14</sup> Das große Werk inspirierte Fasch, und da er fürchtete nicht lange genug zu leben, um ein ebenso monumentales Werk zu komponieren, begann er sofort eine eigene Messe für 16 Stimmen zu schreiben. Er beendete sie innerhalb weniger Wochen, aber revidierte und ergänzte sie innerhalb der nächsten zwei Jahrzehnte immer wieder.<sup>15</sup> Sie wurde seine am meisten gefeierte Komposition und ist bis heute ein unvergleichliches Meisterwerk in der Chorliteratur des späten 18. Jahrhunderts.

Fasch vertonte Kyrie und Gloria der Messe in zehn Sätzen mit einer Gesamtdauer von unter einer halben Stunde. Sechs Sätze sind für 16 Stimmen besetzt und enthalten gelegentlich solistische Partien. Die anderen Sätze sind für verschiedene Kombinationen von Sängern und Solisten geschrieben. Die Gesangsstimmen werden allein durch ein Orgelcontinuo komplettiert.

Die drei Eingangssätze zeigen eine faszinierende Gegenüberstellung von galantem und barockem Stil. Sie klingen, in Anlehnung an ihre liturgische Funktion, wie drei Abschnitte eines größeren Satzes, mit komplementären tonalen Zentren und Motiven. Mit dem vierten Satz überrascht Fasch die Zuhörer, es ist eine dramatische Homage an die Tradition der „Gloria in excelsis Deo“-Intonation, bevor das „Et in terra pax“ gesungen wird. Satz 5 ist schwer fassbar und unstet, er zielt auf den sechsten Satz als den Höhepunkt der Messe. Das klangvolle und virtuose „Laudamus te“ ist für Sopransolo und vier begleitende Chöre gesetzt, als „Aria mit Chor-Accompagnato“. Man schreibt Fasch zu, dieses Genre geschaffen zu haben.<sup>16</sup> Die Nummern 7–9 bilden ein Trio von leichten, galanten Sätzen, die mit angenehmer Einfachheit die angestaute Energie des Werks zerstreuen und die Zuhörer auf das große Finale der Messe vorbereiten. „Cum Sancto Spiritu“ ist eine komplexe Fuge, wenn auch *en miniature*, für alle 16 Stimmen, die einer *Missa solennis* zu Gesicht stehen würde.

170 Jahre nach der Entstehung von Benevolis Komposition äußerte Fasch die Hoffnung, seine Messe würde in 170 Jahren kompositorisch als ebenso kühn angesehen werden. Sein Anspruch erlaubt einen Einblick in die vielfältige Ironie dieser Messvertonung, die weder für ein bestimmtes Ensemble noch für eine bestimmte Fuktion komponiert wurde. Inmitten einer Vielzahl chorischer Gebrauchsmusik schuf Fasch diese Messe als erhabenes Kunstwerk, das zukünftige Generationen aufführen und schätzen würden.<sup>17</sup>

Fasch engagierte zwanzig Freunde und Hofsänger, um das Werk zum ersten Mal einzustudieren. Die ersten drei Proben waren desaströs. Die Messe war zu anspruchsvoll für dieses Ensemble, daher überarbeitete Fasch die Komposition.<sup>18</sup> Die nachfolgenden Proben verliefen ähnlich. Doch anstatt die Partitur weiter zu vereinfachen, beendete Fasch die Proben und legte das Werk für Jahre beiseite, bevor er besser ausgebildete Sänger in der neuen Sing-Akademie um sich geschart hatte. 1791 begannen sie erneut die Messe zu proben, und zunächst war auch diese Besetzung nicht in der Lage, das Werk gut zu singen.<sup>19</sup> Fasch veränderte die Partitur wieder, revidierte das „Quoniam tu solus Sanctus“ und das „Kyrie eleison“ und komponierte „Gratias agimus tibi“ neu.<sup>20</sup> Erst 1793 war die Sing-Akademie stark genug, um die Messe unter der gemeinsamen Leitung von Fasch und Zelter aufzuführen. Für fast 50 Jahre war

sie der einzige Chor, der dieses Werk bei steigender Popularität zu Gehör brachte. Obwohl er anschließend noch weitere Chorwerke schuf, hielt Fasch die 16-stimmige Messe für sein bestes Werk und betrachtete nur sie und seine späteren Werke der Nachwelt für würdig. Kurz vor seinem Tod 1800 vernichtete er alle früheren Kompositionen.

Frühe Kritiken des Werks waren sehr positiv. Erst ab 1829 kam negative Kritik an der Messe auf, als die Menschen sie als nicht mehr repräsentativ für die romantische Ästhetik empfanden.<sup>21</sup> Angesehene Zeitgenossen, u.a. Beethoven, hörten Konzerte der Sing-Akademie mit der 16-stimmigen Messe und bezeichneten die Aufführungen gleichfalls als exquisit.<sup>22</sup> Reichardt veröffentlichte 1791 die Urfassungen des „Kyrie eleison“ und „Christe eleison“ in seiner Zeitschrift *Musicalisches Kunstmagazin*.<sup>23</sup> Dass er das Werk für diese Publikation herausgriff ist bezeichnend und trug zu einer weiten Verbreitung beider Sätze in dieser frühen Fassung bei.<sup>24</sup> Trotzdem wurde die vollständige Spätfassung der Messe erst im Jahr 1839 veröffentlicht. Die Messe blieb während des gesamten 19. Jahrhunderts im Repertoire der Sing-Akademie. Der Kammerchor Stuttgart unter der Leitung von Frieder Bernius produzierte 2009 die erste Einspielung.<sup>25</sup>

## Aufführungshinweise

### Mitwirkende

Die Sätze 1–3, 5–6 und 10 sind mit vier Chören besetzt; die Sätze 4 und 8 für drei bzw. zwölf Solisten. Nr. 7 hingegen ist für einen Chor und Solisten geschrieben und Fasch macht keine Angaben darüber, ob alle Choristen in diesem einen Chor singen sollen, oder ob die reduzierte Anzahl der Chöre nahe legt, dass weniger Sänger mitwirken sollten. Ebenso im sechsstimmigen „Quoniam“ (Nr. 9). Dirigenten sollten bedenken wie die musikalische Wirkung sich ändert, wenn weniger Sänger in den einchörigen Sätzen beteiligt sind, und entscheiden ob dies angebracht, effektiv und wünschenswert ist.

<sup>14</sup> Wahrscheinlich Benevoli's *Missa in diluvio aquarum multarum*. Vgl. Ryan Michael Kelly, „Carl Friedrich Christian Fasch and His Mass for Sixteen Voices with Performance Edition“, D.M.A. Diss. (Michigan State University) 2012, S. 14, Anm. 69. Für eine musikalische Analyse und das ideengeschichtliche Umfeld der Messe von Fasch siehe auch: Ulrich Scheideler, *Komponieren im Angesicht der Musikgeschichte. Studien zur geistlichen a-cappella-Musik in der ersten Hälfte des 19. Jahrhunderts im Umkreis der Sing-Akademie zu Berlin* (= Musikwissenschaft an der Technischen Universität Berlin, 11), Berlin 2010, hier S. 315–371 (Kapitel 2.2) und Jürgen Heidrich, *Protestantische Kirchenmusikanschauung in der zweiten Hälfte des 18. Jahrhunderts. Studien zur Ideengeschichte „wahrer“ Kirchenmusik* (= Abhandlungen zur Musikgeschichte, 7), Göttingen 2001, bes. S. 86–123.

<sup>15</sup> Zelter (wie Anm. 3), S. 26.

<sup>16</sup> Gottfried Eberle, „„Spiegel einer reinen, wahrhaft frommen Seele“: Carl Friedrich Christian Faschs Chormusik für die Sing-Akademie zu Berlin“, in: *Carl Friedrich Christian Fasch (1736–1800) und das Berliner Musikleben seiner Zeit* (= Fasch-Studien, 7), Dessau 1999, S. 195–96.

<sup>17</sup> Zelter (wie Anm. 3), S. 26.

<sup>18</sup> Ebd., S. 26–27.

<sup>19</sup> Adam Adrio, Artikel „Fasch, Christian Friedrich Carl“, in: Friedrich Blume (Hrsg.), *Die Musik in Geschichte und Gegenwart*, Bd. 3, Kassel 1954, Sp. 1859 und Hiller (wie Anm. 8), S. 15.

<sup>20</sup> Lichtenstein (wie Anm. 7), S. VII, XI.

<sup>21</sup> Blaut und Oschmann (wie Anm. 1), Sp. 777.

<sup>22</sup> Adolf Weissmann, *Berlin als Musikstadt: Geschichte der Oper und des Konzerts von 1740 bis Berlin 1911*, Berlin 1911, S. 92–93 und Lichtenstein (wie Anm. 7), S. XI.

<sup>23</sup> *Musicalisches Kunstmagazin*, Band 2 (1791), 8. Stück, S. 106–116 (Kyrie eleison; ohne Titel und Komponistenname) und S. 117–121 („Christe eleison a 2 Cori voci Concertante. C. Fasch“).

<sup>24</sup> Von diesem Druck wurden viele Abschriften gemacht. Siehe „Critical Report“.

<sup>25</sup> Frieder Bernius, *Hohes Lied*, Stuttgart 2009 (CD Carus 83.222).

### Ausführung von Verzierungen

Fasch verwendet Triller, Vorschläge und Doppelschläge. Die Angaben scheinen allerdings innerhalb der Messe uneinheitlich zu sein. Einige Triller sind nur mit einem einfachen *tr*-Zeichen notiert, andere mit Trillerschlängen verlängert. Zum Beispiel die halbe Note des Canto IV in Kyrie I, Takt 4, ist mit einem einfachen Triller versehen. Im gleichen Satz in Takt 20 sind Triller hingegen mit Trillerschlängen für die halben Noten von Alto IV und Tenore IV eingetragen. Vorschlagsnoten sind ebenfalls uneinheitlich notiert. In vielen Fällen hat die Vorschlagsnote den halben Notenwert der Hauptnote, wie beispielhaft in „Et in terra pax“, T. 38–40, Canto I. Doch in T. 41 dieses Satzes geht ein Achtelvorschlag einer halben Note voraus, und ein Sechzehntelvorschlag einer Viertelnote in der Linie des Canto I. Es war nicht unüblich, Ornamente in verschiedenen Arten zu notieren. Da sich jedoch kein vollständiges Autograph der Messe erhalten hat, ist es nicht möglich zu ermitteln, ob Fasch die Notation der Verzierungen absichtlich variierte, um unterschiedliche Ausführungen anzudeuten, oder ob die Verzierungen schlicht in der Partitur ungenau notiert waren. Fasch komponierte die Messe schließlich in einer Zeit, als es für Sänger ganz selbstverständlich war, zu den in der Partitur vermerkten Verzierungen noch weitere hinzuzufügen. Aus diesem Grund sollen Dirigenten und Sänger ermutigt werden, sich mit den zeitgenössischen Konventionen für die Ausführung von Verzierungen vertraut zu machen, und damit, wie die Partitur weiter ausgeziert werden kann.

### Instrumentation

Die Continuo-Stimme der Messe ist eindeutig einer Orgel zugewiesen, und es gibt keine Hinweise, dass andere Instrumente für eine Aufführung zu den Sängern hinzugezogen worden wären. Viele Quellen geben fälschlich an, die Messe sei unbegleitet, trotz ihrer unterstützenden Orgellinie.

### **Danksagung**

Betty Heitzman, Roland Schmidt-Hensel, Matthias Hermann, David C. Rayl und Michael Callahan haben unschätzbare Hilfe bei Nachforschungen geleistet. Der University of Michigan Music Library (USA), Staatsbibliothek zu Berlin – Preußischer Kulturbesitz und der Diözesanbibliothek Münster sei gedankt, dass sie mir Zugang zu den Quellen für diese Edition gewährt haben.

Chester Springs, PA, Herbst 2013  
Übersetzung: Julia Rosemeyer

Ryan Michael Kelly

## Foreword

### Carl Fasch's biography

Carl Friedrich Christian Fasch was born in Zerbst on November 18, 1736. He studied music first with his father, the renowned Zerbst *Kapellmeister* Johann Friedrich Fasch; Carl taught himself how to compose fugues. In 1750 he left home for three years to study violin, harpsichord, and organ under Johann Christian Hertel and Carl Höckh.<sup>1</sup> While away studying, his fine keyboard skills drew the attention of Franz Benda, concertmaster for King Frederick the Great of Prussia. On Benda's recommendation, the King offered Fasch the court's second harpsichordist position. Fasch accepted it in 1756 and remained in the court's employ until his death in 1800.

Though charismatic with a robust laugh and wry sense of humor, he was also very shy, with few friends. He never married nor had children. His closest friend was Carl Zelter, who took lessons from Fasch between 1784–86 and cared for him in his later years.<sup>2</sup> His keyboard skills and musicianship were highly esteemed, particularly for how he subtly elicited fine performances from soloists he accompanied and how he easily adapted to their manners of playing.<sup>3</sup> He also received praise for his unusually refined conducting of large groups of singers.<sup>4</sup>

Because he was hired as a keyboardist second to C. P. E. Bach and was not required to compose, Fasch's court duties were minimal. He never had enough responsibility to occupy his time and faculties. Early on, he accompanied the king's daily flute playing, and he briefly acted as interim director of the court's opera.<sup>5</sup> But war consumed much of Frederick's time and resources, leaving Fasch with little to do and little money to live on. He supplemented his income by giving students private composition, voice, and harpsichord lessons. These lessons eventually lay the framework for his greatest professional achievement – founding the Sing-Akademie zu Berlin.

In 1790, two or three music aficionados began gathering at the home of Charlotte Dietrich, one of Fasch's voice students, for entertainment and singing.<sup>6</sup> By mid-year, twelve to sixteen singers regularly gathered, meeting in another home, to sing four, five, and six-part pieces by Fasch and to receive his vocal coaching.<sup>7</sup> The singers formally organized themselves as an ensemble in 1791 and adopted their name, Sing-Akademie zu Berlin, in 1793. They gave their first performance in 1792 at the Berlin Marienkirche. They gained immediate recognition, not only for their fine sound, but also because they offered the first mixed choir performance in a church in Berlin and perhaps all of Germany.<sup>8</sup> Fasch conducted the ensemble until 1797.<sup>9</sup> They sang only sacred music, and only music he composed until 1794 when they began rehearsing the works of Allegri, J. S. Bach, Graun, Handel, Mozart, and others. Drawn to complex multi-voice church music since a young age, Fasch envisioned that the Sing-Akademie would "advance the art" of sacred choral music.<sup>10</sup> The growing ensemble, already 100 singers by 1797, was comprised of *Dilettanten* and professional singers. They were noted to be the finest choral ensemble in Germany and particularly recognized for their fine intonation and unmatched performances of the music of J. S. Bach and Handel.<sup>11</sup>

Though officially the Sing-Akademie's artistic director until his death, Fasch grew extremely ill in 1797 and delegated the leadership of all rehearsals to Zelter. He died August 3, 1800 and was buried at the

Jerusalem Friedhof near the Hallesches Tor in Berlin on August 7. On October 8, the Sing-Akademie performed Mozart's Requiem in memoriam and used the concert's proceeds to establish a memorial fund to support annually one needy family.<sup>12</sup> Zelter wrote Fasch's biography in 1801 and the Sing-Akademie published his extant works with the Berlin *Musikalienhändler* Traugott Trautwein in the late 1830s.<sup>13</sup>

### About the Mass for sixteen voices

In 1783, fellow court musician Johann Friedrich Reichardt visited Italy and returned with a copy of a sixteen-voice mass by Orazio Benevoli that he gifted to Fasch.<sup>14</sup> The grand work inspired Fasch, and fearing he would not live long enough to compose an equally

<sup>1</sup> Stephan Blaut and Susanne Oschmann, article "Fasch, Carl Friedrich Christian," in: *Die Musik in Geschichte und Gegenwart*, Ludwig Finscher (ed.), Personenteil vol. 6, Kassel, 2002, col. 775.

<sup>2</sup> Hans-Günter Ottenberg, article "Zelter, Carl Friedrich," in: *Grove Music Online. Oxford Music Online* <accessed September 1, 2013>.

<sup>3</sup> Charles Burney, *An Eighteenth-Century Musical Tour in Central Europe and The Netherlands*, London, 1775 (reprint: London, 1959), p. 204; Gottfried Eberle, *200 Jahre Sing-Akademie zu Berlin: Ein Kunstverein für die heilige Musik*, Berlin, 1991, p. 23; Carl Friedrich Zelter, *Karl Friedrich Christian Fasch*, Berlin, 1801, p. 46.

<sup>4</sup> Zelter (as in note 3), pp. 30–31 and Georg Schünemann, *Die Singakademie zu Berlin*, Regensburg, 1941, p. 20.

<sup>5</sup> Adolf Bernhard Marx, article "Fasch, Carl Friedrich Christian," in: Gustav Schilling (ed.), *Encyclopädie der gesammten musikalischen Wissenschaften, oder Universal-Lexicon der Tonkunst*, vol. 2, Stuttgart, 1835, p. 660.

<sup>6</sup> Marx (as in note 5), p. 662; Eberle (as in note 3), p. 26; Zelter (as in note 3), p. 29.

<sup>7</sup> Heinrich Lichtenstein, *Zur Geschichte der Sing-Akademie in Berlin: Nebst einer Nachricht über das Fest am fünfzigsten Jahrestage ihrer Stiftung und einem alphabetischen Verzeichnis aller Personen, die ihr als Mitglieder angehört haben*, Berlin, 1843), p. V; Beverly Jerold, "Fasch and the Beginning of Modern Artistic Choral Singing," in: *Bach: the Journal of the Riemenschneider Bach Institute, Baldwin-Wallace College* 35 (2004), p. 75.

<sup>8</sup> Dietmar Hiller, "Karl Friedrich Fasch und die Gründung der Berliner Singakademie," in: *Karl Friedrich Christian Fasch (1736–1800). Bericht über die wissenschaftliche Konferenz in Zerbst am 16. und 17. April 1988 aus Anlaß des 300. Geburtstages von Johann Friedrich Fasch (1688–1758)* (= Studien zur Aufführungspraxis und Interpretation der Musik des 18. Jahrhunderts, 41), Michaelstein/Blankenburg, 1989, p. 16 and Ingeborg Allihn, "'Öffentliche Schauspiele und Lustbarkeiten': Das Berliner Musikleben in der zweiten Hälfte des 18. Jahrhunderts," in: *Carl Friedrich Christian Fasch (1736–1800) und das Berliner Musikleben seiner Zeit* (= Fasch-Studien, 7), Dessau, 1999, p. 148.

<sup>9</sup> Ernst Ludwig Gerber, article "Fasch (Carl Friedrich Christian)," in: *Neues historisch-biographisches Lexikon der Tonkünstler*, vol. 2, Leipzig, 1812 (reprint: Graz, 1966), pp. 83–84.

<sup>10</sup> Marx (as in note 5), p. 660 and Zelter (as in note 3), p. 32.

<sup>11</sup> "The Choral Societies of Berlin," in: *The Musical Times and Singing Class Circular* 37 (1896), p. 318; Roderich Fuhrmann, "Carl Friedrich Christian Fasch: Ein Komponist zwischen Rokoko und Historismus (1736–1800)," in: *Fasch und die Musik im Europa des 18. Jahrhunderts* (= Fasch-Studien, 4), Weimar, 1995, p. 155; Eberle (as in note 3), p. 32; Jerold (as in note 7), p. 79.

<sup>12</sup> Fuhrmann (as in note 11), p. 160 and Zelter (as in note 3), p. 35.

<sup>13</sup> *Sämtliche Werke von Karl Christian Friedrich Fasch*, vol. 1–7, Berliner Sing-Akademie (ed.), Berlin: Trautwein, ca. 1837–39.

<sup>14</sup> Likely Benevoli's *Missa in diluvio aquarum multarum*. See Ryan Michael Kelly, "Carl Friedrich Christian Fasch and His Mass for Sixteen Voices with Performance Edition," D.M.A. diss. (Michigan State University), 2012, p. 14, note 69. For musical analysis and the context of the history of ideas of the Mass by Fasch, see also: Ulrich Scheideler, *Komponieren im Angesicht der Musikgeschichte. Studien zur geistlichen a-cappella-Musik in der ersten Hälfte des 19. Jahrhunderts im Umkreis der Sing-Akademie zu Berlin* (= Musikwissenschaft an der Technischen Universität Berlin, 11), Berlin, 2010 here pp. 315–371 (chapter 2.2), and Jürgen Heidrich, *Protestantische Kirchenmusikanschauung in der zweiten Hälfte des 18. Jahrhunderts. Studien zur Ideen-geschichte "wahrer" Kirchenmusik* (= Abhandlungen zur Musikgeschichte, 7), Göttingen, 2001, esp. pp. 86–123.

monumental work, he immediately began composing his own Mass for sixteen voices. He completed it in just a few weeks, though he revised and added to it over the next two decades.<sup>15</sup> It became his most acclaimed composition and remains an unparalleled choral masterwork of the late-eighteenth century.

Fasch set the Kyrie and Gloria of the mass in ten movements; their combined duration is under thirty minutes. Six movements are scored for sixteen voices with occasional soloists; the other movements are for varying combinations of voices and soloists. The voices are complemented with a lone organ *basso continuo*.

The opening three movements demonstrate a fascinating juxtaposition of *galant* and Baroque styles. They also sound like three sections of one larger movement, with complementary tonal centers and motives, reminiscent of their liturgical association. Fasch surprises listeners with movement four, a dramatic homage to the practice of intoning the “Gloria in excelsis Deo” before singing the “Et in terra pax.” Movement five, elusive and nomadic, points forward to the Mass’s acme, the sixth movement. The tuneful and virtuosic “Laudamus te” is scored for soprano soloist accompanied by four choirs, an “aria with choir accompaniment” – a genre Fasch has been credited with creating.<sup>16</sup> Movements seven through nine are a trio of relaxing, *galant* movements that, with delightful simplicity, diffuse the work’s accumulated energy and prepare listeners for the Mass’ grand *finale*. The “Cum Sancto Spiritu” is a complex, albeit miniature, fugue for all sixteen voices in a manner worthy of a *missa solennis*.

Composing approximately 170 years after Benevoli, Fasch said he hoped his Mass would be considered 170 years later as compositionally daring; this ambition offers insight into the Mass’ many ironies. He did not compose it for an ensemble or function. Amidst a sea of utilitarian, concerted choral works, he composed it to be an elevated work of art that future generations would perform and esteem.<sup>17</sup>

Fasch gathered twenty friends and court singers to rehearse the work for the first time; its first three rehearsals were disastrous. The Mass was too challenging for them, so he revised the work.<sup>18</sup> Subsequent rehearsals failed similarly. Rather than simplify it further, he stopped rehearsing and shelved it for years before gathering more highly trained singers in the new Sing-Akademie. They began rehearsing it in 1791, and initially they too were unable to sing it well.<sup>19</sup> Fasch altered it again, revising the “Quoniam tu solus Sanctus” and “Kyrie eleison” and newly composing the “Gratias agimus tibi.”<sup>20</sup> By 1793, the Sing-Akademie was strong enough to perform the Mass and under Fasch’s and Zelter’s combined directorship, they exclusively performed and popularized it for nearly fifty years. Though he composed subsequent choral works, Fasch considered the Mass his finest work and deemed only it and his later compositions as worthy of posterity. Nearing his death in 1800, he gathered all of his earlier compositions and destroyed them.

Early criticism of the work was very positive. Negative criticism of the work gained attention in 1829 as people decried it for not representing the aesthetics of Romanticism.<sup>21</sup> Notables, including Beethoven, heard the Sing-Akademie perform the work, and their performances were likewise recognized as exquisite.<sup>22</sup> Reichardt published germinal versions of the “Kyrie eleison” and “Christe eleison” in his 1791 periodical *Musicalisches Kunstmagazin*.<sup>23</sup> That Reichardt singled it out and published it is significant and contributed to a wide dissemination of both movements in this early version.<sup>24</sup>

However, it was not until 1839 that the Mass was published in its mature entirety. The Mass remained in the Sing-Akademie’s repertoire throughout the nineteenth century. Kammerchor Stuttgart, with Frieder Bernius conducting, produced its premiere recording in 2009.<sup>25</sup>

## Suggestions for Performance

### Performing forces

Movements 1–3, 5–6, and 10 are clearly scored for four choruses; movements 4 and 8 are scored for three and twelve soloists, respectively. Movement 7, however, is scored for one chorus with soloists, and Fasch gives no indication whether all the choristers are to sing in this one chorus or if the reduced number of choruses suggests that fewer singers should participate. This is also the case for the six-part “Quoniam” (No. 9). Conductors should consider how the musical character will change by using fewer singers in the single-chorus movements and decide if that is appropriate, effective, and desirable.

### Ornament realization

Fasch calls for trills, appoggiaturas, and turns. However, the markings seem to be inconsistent throughout the Mass. Some trills are notated with a simple *tr* and others are extended. For example, in Kyrie I m. 4, a simple trill is attached to a Canto IV half note; yet, in the same movement in m. 20, an extended trill is attached to Alto IV and Tenore IV half notes. Similarly, appoggiaturas are inconsistently notated. In many cases, the value of the appoggiatura is half that of the note it precedes, as evidenced in “Et in terra pax” mm. 38–40, Canto I. Yet, in m. 41 of that movement, an eighth-note ornament precedes a half note and a sixteenth-note ornament precedes a quarter note in the Canto I line. It was not uncommon for ornaments to be notated in different manners; however, as there is no extant autograph manuscript of the entire Mass, it is impossible to ascertain whether Fasch intentionally varied his ornament notation to suggest varied realizations or if the ornaments were simply inconsistently notated on the score. Finally, Fasch composed the Mass at a time when it was quite common for singers to sing ornaments in addition to those suggested in the score. Thus, conductors and singers are encouraged to familiarize themselves with contemporary conventions for realizing notated ornaments as well as for how to further ornament the score in performance.

<sup>15</sup> Zelter (as in note 3), p. 26.

<sup>16</sup> Gottfried Eberle, “‘Spiegel einer reinen, wahrhaft frommen Seele’: Carl Friedrich Christian Faschs Chormusik für die Sing-Akademie zu Berlin,” in: *Carl Friedrich Christian Fasch (1736–1800) und das Berliner Musikleben seiner Zeit* (= Fasch-Studien, 7), Dessau, 1999, pp. 195–96.

<sup>17</sup> Zelter (as in note 3), p. 26.

<sup>18</sup> *Ibid.*, pp. 26–27.

<sup>19</sup> Adam Adrio, article “Fasch, Christian Friedrich Carl,” in: *Die Musik in Geschichte und Gegenwart*, Friedrich Blume (ed.), vol. 3, Kassel, 1954, col. 1859 and Hiller (as in note 8), p. 15.

<sup>20</sup> Lichtenstein (as in note 7), p. VII, XI.

<sup>21</sup> Blaut and Oschmann (as in note 1), col. 777.

<sup>22</sup> Adolf Weissmann, *Berlin als Musikstadt: Geschichte der Oper und des Konzerts von 1740 bis Berlin 1911*, Berlin, 1911, pp. 92–93 and Lichtenstein (as in note 7), p. XI.

<sup>23</sup> *Musicalisches Kunstmagazin*, Band 2 (1791), 8. Stück, pp. 106–116 (Kyrie eleison; without the title and composer’s name) and pp. 117–121 (“Christe eleison a 2 Cori voci Concertante. C. Fasch”).

<sup>24</sup> Many copies were made from this printing. See the Critical Report.

<sup>25</sup> Frieder Bernius, *Hohes Lied*, Stuttgart, 2009 (CD Carus 83.222).

### Instrumentation

The Mass' continuo line is explicitly scored for organ and there is no known documentation of instances in which any other instruments performed the Mass with the singers. Many sources describe the Mass as unaccompanied, despite its supporting organ line.

### **Acknowledgements**

Betty Heitzman, Roland Schmidt-Hensel, Matthias Hermann, David C. Rayl, and Michael Callahan offered invaluable research assistance. The University of Michigan Music Library (U. S. A.), Staatsbibliothek zu Berlin – Preußischer Kulturbesitz (Germany), and Diözesanbibliothek Münster (Germany) offered access to the reference scores for this edition.

Chester Springs, PA, autumn 2013

Ryan Michael Kelly



N. 2. *Christe eleison.*

The musical score is written in a single system with four groups of four staves each, representing four choirs (CORO I to IV). Each choir has parts for Canto, Alto, Tenore, and Basso. The organ part is at the bottom. The lyrics "Christe, eleison!" are written under the vocal lines. The score includes dynamic markings like "pia." and "cresc." and performance instructions like "Solo-Stimmen".

Abb. 1: Beginn von Nr. 2 „Christe eleison“, Seite 11 der Erstausgabe „MISSA | a 16 Voci | in | Quattro Cori. | composta | da | Carlo Fasch“ (Quelle A), die 1839 in Berlin bei T. Trautwein erschien.

Beginning of No. 2 “Christe eleison,” page 11 of the first edition “MISSA | a 16 Voci | in | Quattro Cori. | composta | da | Carlo Fasch” (source A) which was published in 1839 by T. Trautwein in Berlin.

Sächsische Landesbibliothek – Staats- und Universitätsbibliothek Dresden, Signatur: Mus.3393.D.500.

ni am tu so — lus Do — minus.  
 Do — minus.  
 tus, tu so — lus Do — minus, tu so — lus al — tis si mus.  
 Quo — ni — am tu so — lus, tu so — lus al —  
 tus. tu so — lus al —  
 Quo — ni — am tu so — lus Do — minus, tu  
 tu so lus tu so — lus al tis si mus,  
 so — lus san ctus, tu so — lus al tis si mus, tu  
 pia. pia. pia.  
 tu so lus san ctus, tu so — lus al — tis si mus, tu  
 tis si mus, tu so lus san ctus, tu so — lus al — tis si mus, tu  
 tis si mus, tu so lus san ctus, tu so lus al tis si mus,  
 ffor. ffor. ffor. ffor. ffor.  
 so — lus san ctus, tu so — lus, tu so — lus al — tis si mus,  
 6/4 5/3 b7 forte 6/4 7 6 5 #

Abb. 2: Takte 31–39 von Nr. 9 „Quoniam tu solus Sanctus“, Seite 110 der Erstausgabe. / Measures 31–39 of No. 9 “Quoniam tu solus Sanctus,” page 110 of the first edition.

Sächsische Landesbibliothek – Staats- und Universitätsbibliothek Dresden, Signatur: Mus.3393.D.500.

# Missa a 16 voci

## 1. Kyrie eleison

Carl Friedrich Christian Fasch  
1736–1800

The musical score is arranged in four systems, each representing a choir (Coro I to Coro IV). Each system contains four vocal staves: Canto (Soprano), Alto, Tenore (Tenor), and Basso (Bass). The music is in common time (C) and begins with a dynamic marking of *p* (piano) and a *cresc.* (crescendo) instruction. The lyrics are: Ky - ri - e - e - le - i - son, e - le - i - son, e - le - i - son, e - le - i - son. The score includes various musical notations such as notes, rests, and dynamic markings. A large watermark 'PROBE PART' is overlaid diagonally across the page. In the bottom right corner, there is a logo of an open book with a magnifying glass over it.

Ausgabqualität gegenüber Original evtl. gemindert • Evaluation Copy - Quality may be reduced • Carus-Verlag

Aufführungsdauer / Duration: ca. 23 min.

© 2014 by Carus-Verlag, Stuttgart – CV 27.083

Vervielfältigungen jeglicher Art sind gesetzlich verboten. / Any unauthorized reproduction is prohibited by law.

Alle Rechte vorbehalten / All rights reserved / Printed in Germany / www.carus-verlag.com

Generalbassaussetzung /  
herausgegeben von  
Ryan Michael Kelly

I

*f*  
ri - - - e, Ky - ri - e - - e - le - i - son,  
*ff*  
Ky - ri - e - - e - le - - i - son,  
*f*  
ri - - - e, Ky - ri - e e - le - i - son,  
*f*  
e, Ky - ri - e - - e - le - i - son,

II

*f*  
ri - - - e, Ky - ri - e e - le - i - son,  
*cresc.*  
le - - - i - son, e - le - i -  
*ff*  
Ky - ri - e - - e - le - i - son, e - le  
*cresc.*  
ri - - - e e - le  
*f*  
Solo  
Ky - ri -

III

- ri - e  
e - - e - le - i - son, Solo  
*f*  
i - son, Ky - ri - e,  
Solo  
Ky - ri - e,  
Solo  
le - i - son, Ky - ri - e,  
Solo

IV

le  
Tutti  
- - - i - son,  
e - le - - i - son,  
Tutti  
Ky - ri - e e - le - i - son,  
e e - le - i - son, e - le - i - son,

6 5 7 6 5  
4 3 5 4 4 3

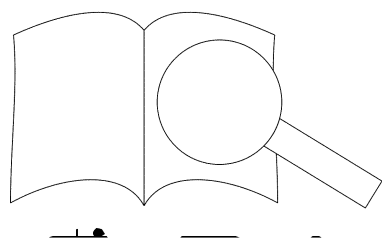

PROBENPARTIUR  
Ausgabequalität gegenüber Original evtl. gemindert • Evaluation Copy - Quality may be reduced • Carus-Verlag

I

Ky - ri - e, Ky - ri - e,  
 Ky - ri - e, Ky - ri - e,  
 Ky - ri - e, Ky - ri - e,  
 Ky - ri - e, Ky - ri - e,

II

Ky - ri - e, Ky - ri - e,  
 Tutti  
 e e - le - i - son, Ky - ri - e, Ky - ri - e,  
 Tutti  
 e e - le - i - son, Ky - ri - e, Ky - ri - e,  
 Tutti  
 e e - le - i - son, Ky - ri - e, Ky

III

Tutti  
 Ky - ri - e,  
 Tutti  
 Ky  
 Ky  
 Ky - ri - e,  
 Ky - ri - e,  
 Solo tr  
 Ky - ri -  
 Solo  
 Ky - ri -  
 Solo  
 Ky - ri -  
 Solo

IV

Tutti  
 Ky - ri - e e - le - i - son,  
 Solo  
 Ky - ri - e, Ky - ri - e e - le - i - son,  
 Tutti  
 Solo  
 Ky - ri - e, Ky - ri - e e - le - i - son,  
 Tutti  
 Solo  
 Ky - ri - e, Ky - ri - e e -

3 6 7 7 6 5

7 6 6

PROBE  
 Ausgabqualität gegenüber Original evtl. gemindert • Evaluation Copy - Quality may be reduced • Carus-Verlag

17

I

Solo Ky - ri - e, Ky - ri - e e - le - i - son, e - le - i - son,

Solo Ky - ri - e, Ky - ri - e e - le - i - son, e - le - i -

Solo Ky - ri - e, Ky - ri - e e - le - i - son, Tutti

Solo Ky - ri - e, Ky - ri - e e - le - i - son, e - le

II

Ky - ri - e,

Ky - ri - e,

Ky - ri - e

Ky - ri - e

- i - son, e -

III

Tutti

e, Ky - ri - e, Tutti

e, Ky - ri - e, Tutti

e, Ky - ri - e, Tutti

e, Ky - ri - e, Tutti

e - le - i -

e - le - i - son, e -

IV

- ri - e e - le - i -

Tutti

Ky - ri - e

6 [5#] # t.s. [7] [5#] [#]

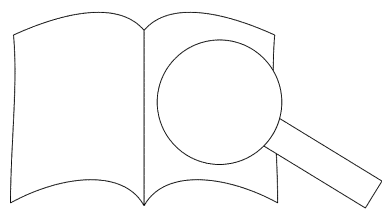

PROBENPARTITUR

Ausgabequalität gegenüber Original evtl. gemindert • Evaluation Copy - Quality may be reduced • Carus-Verlag

I

Solo

Ky - ri - e e - le - - - - - i -

son, Ky - ri - e e - le - - - - - i -

son, Ky - ri - e e - le - - - - - i -

le - i - son, Ky - ri - e, Ky - ri - e, Ky - ri - e e

II

Ky - ri - e, Ky - ri - e le

Ky - ri - e, Ky - ri - e

son, Ky - ri - e le - i -

le - i - son, Ky - ri - e,

III

Ky - ri - e, Ky - ri - e,

Ky - ri - e, Ky - ri - e,

son, Ky - ri -

le - i - son,

IV

- ri - e,

Ky - ri - e,

*p*

3 6 5 3# 6 7 6 5 7

4 4 4 4 5 3 3

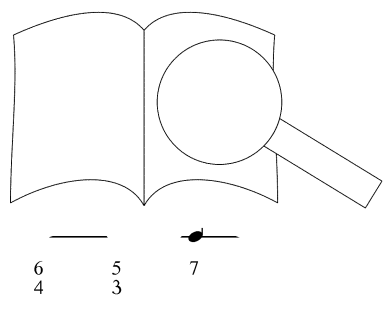

PROBENPARTITUR

Ausgabequalität gegenüber Original evtl. gemindert • Evaluation Copy - Quality may be reduced • Carus-Verlag

I

son, Ky - ri - e

son, Ky - ri - e,

son, Ky - ri - e

Tutti

II

son, Ky - ri - e, Ky

son, Ky - ri - e, Ky - ri - e - i -

son, e - le - i - son, Ky - ri e - le - i -

Ky - ri - e, - e - le - i -

*f*

III

Ky - ri - e, e,

Ky - ri - ri - e e - le - i -

Ky - ri - e e - le - i -

Ky Ky - ri - e,

IV

Ky - ri - e,

ri - e, Ky - ri - e,

- ri - e, Ky - ri - e,

- le - i - son, Ky - ri - e e - le - i - son,

*f*

Handwritten musical notation with a slur over a series of notes.

47 8 64 5 6 7 8  
6b 4 4 3 3 6 7 8  
4 3 4 3

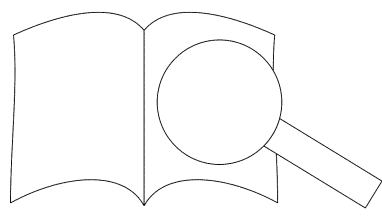

PROBEN  
Ausgabequalität gegenüber Original evtl. gemindert • Evaluation Copy - Quality may be reduced • Carus-Verlag



I

e - le - - i - son, e - le - i - son, e - le - - i - son.

Ky - ri - e e - le - i - son, e - le - i - son.

*Tutti*

e - le - - i - son, e - le - - i - son.

e - le - - i - son, e - le - - i - son, e - le - i -

II

son, e - le - - i - son, i

son, e - le - i - son, e - le - i - le

son, e - le - i - son, e - i son.

son, e - le son - - i - son.

III

Ky - ri - e e - le - - i - son, son, e - le - i - son.

son, e - le - i - son, e - le - i - son.

son, Ky - ri - e e - le - i - son, e - le - i - son.

Ky - ri - e e - le - i - son.

IV

Ky - ri - e - le - i - son, e - le - i - son.

Ky - ri e - le - i - son, e - le - i - son.

i - son, Ky - ri - e e - le - i - son, e - le - i - son.

e - le - i - son, e - le -

t.s.

6 5 2 6 5 6 6 5 5

7 6 7 6 5 7 5



## 2. Christe eleison

Solo

Tutti

Canto

Alto

Tenore

Basso

Coro I

Chri - ste e - le - i - son,

*p* Solo *cresc.* *tr*

Chri - ste e - le - i - son,

8 Chri - ste e - le - i - son,

Coro II

Canto

Alto

Tenore

Basso

Coro III

Canto

Alto

Tenore

Basso

Coro IV

Canto

Alto

Solo

Tutti

Chri - ste e - le - i - son, e - lei - son,

Solo

Tutti

Chri - ste e - le - i - son, e - lei - son,

*p* Solo *cresc.* *tr* Tutti

Chri - ste e - le - i - son,

6 5 4 6 5 4 6 7 6 7 5 4



7

I

lei - son, Chri - ste e - le i - son, Chri - ste

lei - son, e - le - i - son, Chri - ste

lei - son, Chri - ste e - le - i - son,

lei - son, Chri - ste e - le - i - son,

*Solo* *tr* *f*

*p* *Solo* *f*

*Solo* *p*

*Solo* *p* *f*

II

son,

son,

son,

son,

III

son,

son,

son,

son,

IV

son, Chri - ste e - le - i - son,

e - lei - son, Chri - ste e - le - i - son,

Chri - ste e

*Solo*

*p*

5 6 6 b7 6 6 b7 [-] 6

4 5 5 5 4 4 4 3

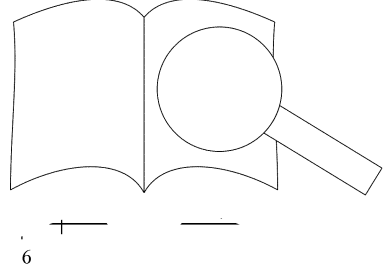

PROBENPARTITUR

Ausgabequalität gegenüber Original evtl. gemindert • Evaluation Copy - Quality may be reduced • Carus-Verlag

14

I

*Tutti* *Solo*

e - le - i - son, e - lei-son, Chri - ste e - lei - -

*Tutti* *Solo*

e - le - i - son, e - lei-son, Chri - ste e - le - -

*Tutti* *Solo*

e - lei-son, Chri - ste e - lei - -

*Tutti*

e - le - i - son, e - lei-son,

II

*p*

e - le - i - son.

*p*

e - le - i - son.

*p*

e - le - i - son.

III

*p*

e - le - i

*p*

e - le

*p*

e

IV

lei - son,

*Tutti*

e - lei - son,

*Tutti*

e - lei - son,

*f*

*p*

6 7

6

8

6

4

2

8

6

5

6

5

6

5

6

5

6

5

4

3

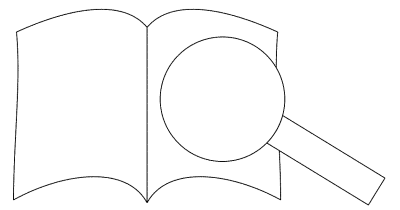

I

- - son, Chri - ste e - le - i - son, Chri - ste e - le - i -

- - - i - son, e - le - i - son, e - le - i - son, e - le -

- - son, e - le - i - son, Chri - ste e - le

Solo

Chri - ste e - le - i - son, Chri - ste

IV

*Tutti*

Chri - ste e - le - i - son,

Chri - ste e - le - i -

*p*

e - le - son,

Chri - ste - i

7 7 4 3 6 5 3 4

I

son, e - le - i - son, le - i - son, e - le - i -

- i - son, e - lei - le - i - son, e - le - i -

son, e - le - i - son, e - le - i -

son, e - le - i - son, e - le -

*p* *cresc.* *tr*

*cresc.*

IV

e - lei - son, e -

e - le - i -

e -

*pp*

7 6 5 7 6 4 6 5 6 4

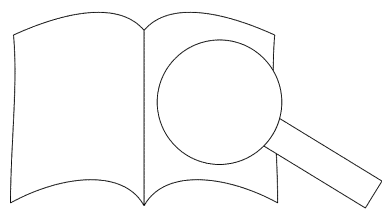

PROBENPAPIER

Ausgabequalität gegenüber Original evtl. gemindert • Evaluation Copy - Quality may be reduced • Carus-Verlag

I

son, e - le - - - i - son, e -

son, Chri - ste, Chri - ste e - le - i - son, e -

son, e - le - - - i - son,

IV

lei - son, e - le -

son, e

lei - son,

lei - son, e -

5 4# 6 6# 6 5b 9 8 6 6 3 6 3 6 3 5 3

I

le - - - i - son, Chri - ste e - le - i -

lei - son, e - lei - son, Chri - ste e - le - i -

e - le i - son, Chri - ste e - le - i -

IV

- - - i - son, Chri - ste e - le - - - i -

- - - i - son, Chri - ste, Chri - - - i -

- - - i - son, Chri - ste, C

7 9 3 9 8 9 8 7 6 7 4 4

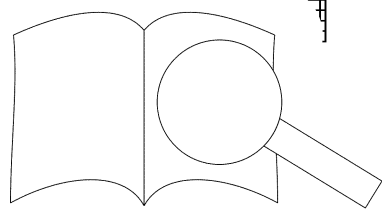

### 3. Kyrie eleison

**Coro I**

Canto: *Tutti* Ky - ri - e, Ky - ri - e e - le - i - son,

Alto: *son. Tutti* Ky - ri - e, Ky - ri - e e - le - i - son,

Tenore: *Tutti* *son. Ky - ri - e,* Ky - ri - e e - le - i - son,

Basso: *Solo: son. Tutti* Ky - ri - e, Ky - ri - e e - le - i - son,

**Coro II**

Canto: *Tutti* Ky - ri - e e - le - i - son,

Alto: *Tutti* Ky - ri - e, Ky - ri - e

Tenore: *Tutti* Ky - ri - e, Ky - ri - e

Basso: *Tutti* Ky - ri - e e - le - i - son,

**Coro III**

Canto: *Tutti* Ky - ri - e, Ky - ri - e e - le - i - son,

Alto: *Tutti* Ky - ri - e, e - le - i - son,

Tenore: *Tutti* Ky - ri - e, e - le - i - son,

Basso: *Tutti* Ky - ri - e, e - le - i - son,

**Coro IV**

Canto: Ky - ri - e, Ky - ri - e e -

Alto: Ky - ri - e, Ky - ri - e e -

*Tutti* Ky - ri - e, Ky - ri - e,

*Organo*

7 8 7 6 5 7[#] 8  
 6 5 4 4 5 6 5  
 4 3 4 4 4 4 3  
 2 3 4 4 4 2 4

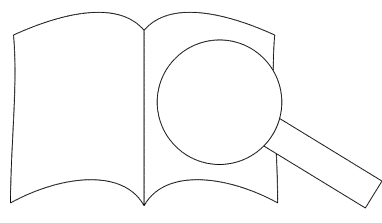

I

Ky - ri - e e - le - i - son,

Ky - ri - e e - le - i - son,

Ky - ri - e, Ky - ri - e e - le - i - son,

Ky - ri - e e - le - i

II

Ky - ri - e e - le - i - son,

Ky - ri - e e - le - i - son,

Ky - ri - e,

Ky - ri - e e - le - i - son,

Ky - ri -

III

Ky - ri - e e - le - i - son,

Ky - ri - e e - le - i - son,

Ky - ri - e,

Ky - ri - e

Ky - ri -

Ky - ri -

Ky - ri -

Ky - ri -

IV

Ky - ri -

Ky - ri -

7

5 3 7 6 6 6 9 6 3 6 6 9 6 7 7 6 5 3  
4 3 5 4 5b 5 5 5 5 5 4 - 3

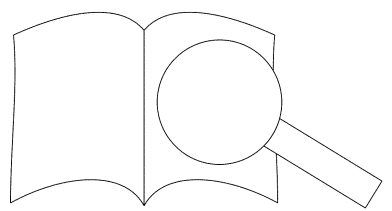

PROBENFÜR  
Ausgabequalität gegenüber Original evtl. gemindert • Evaluation Copy - Quality may be reduced • Carus-Verlag



I

Ky - ri - e e - le - i - son, Ky - ri - e e - le - i - son, Ky - ri - e

Ky - ri - e e - le - i - son, Ky - ri - e e - le - i - son, Ky - ri - e

Ky - ri - e e - le - i - son, Ky - ri - e e - le - i - son, Ky - ri - e,

Ky - ri - e

II

e, Ky - ri - e, Ky - ri - e

e, Ky - ri - e, Ky - ri - e

e, Ky - ri - e, Ky - ri - e

e, Ky - ri - e, Ky - ri - e

III

e, Ky - ri - e, e, Ky - ri - e e - le - i -

e, Ky - ri - e, Ky - ri - e e - le - i -

e, Ky - ri - e, Ky - ri - e e - le - i -

e, Ky - ri - e, Ky - ri - e

IV

e, Ky - ri - e, ri - e, Ky - ri - e, Ky - ri - e, Ky - ri - e, Ky - ri - e, Ky - ri - e

e, Ky - ri - e, ri - e, Ky - ri - e, Ky - ri - e, Ky - ri - e, Ky - ri - e, Ky - ri - e

e, Ky - ri - e, ri - e, Ky - ri - e, Ky - ri - e, Ky - ri - e, Ky - ri - e, Ky - ri - e

e, Ky - ri - e, ri - e, Ky - ri - e, Ky - ri - e, Ky - ri - e, Ky - ri - e, Ky - ri - e

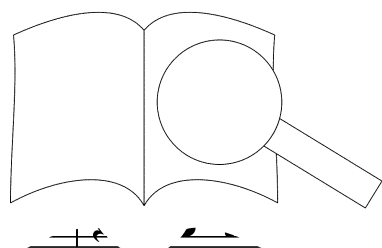

**I**

Solo Tutti

e - le - i - son, e - le - i - son, e -

Solo

e - le - i - son, e - le - i - son,

Solo Tutti

8 Ky - ri - e e - le - i - son,

Solo

Ky - ri - e e - le - i - son,

**II**

son,

son,

son,

son,

Ky - ri - e e -

**III**

son,

son,

ri - e e - lei - son,

Ky - ri - e e - lei - son,

Ky - ri - e,

Ky - ri - e e - lei - son,

**IV**

Ky - ri - e e - le - i - son,

Ky - ri - e e - lei - son,

Ky - ri - e e - lei - son,

Ky - ri - e e - lei - son,

4# 6

2 5

PROBENPARTITUR

Ausgabequalität gegenüber Original evtl. gemindert • Evaluation Copy - Quality may be reduced • Carus-Verlag

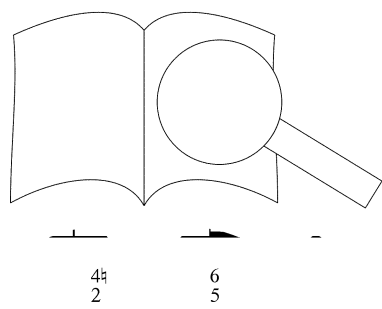

I

le - i - son, Ky - ri -

*Tutti*

e - le - i - son, Ky - ri -

le - i - son, Ky

*Tutti*

e - le - i - son,

II

le - i - son,

le - i - son,

e,

lei - son,

Ky

ri - e,

III

Ky - ri - e,

Ky - ri - e,

IV

Ky - ri -

Ky - ri -

Ky - ri -

6 6 9 3 6 3 6 3 3 6 7 6 5 4

5 5 5 5 5 5 5 5 5 5 4 4 4

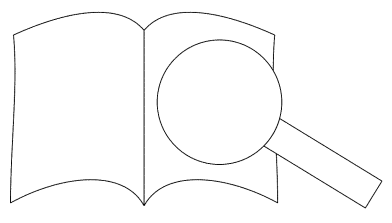

47  
6  
4  
2

PROBENPARTITUR  
Ausgabequalität gegenüber Original evtl. gemindert • Evaluation Copy - Quality may be reduced • Carus-Verlag

I

II

III

IV

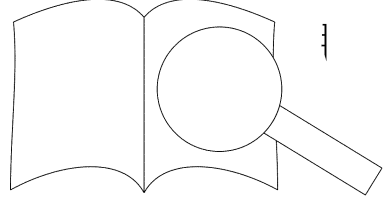

PROBENFÜR

Ausgabequalität gegenüber Original evtl. gemindert • Evaluation Copy - Quality may be reduced • Carus-Verlag

I

son, Ky - ri - e e - le - i - son.

son, Ky - ri - e e - le - i - son.

son, Ky - ri - e e - le - i - son.

e, Ky - ri - e.

II

Ky - ri - e, Ky - ri - e e - le - i - son.

Ky - ri - e, Ky - ri - e e - le - i - son.

Ky - ri - e, Ky - ri - e e - le - i - son.

Ky - ri - e, Ky - ri - e e - le -

III

son, Ky - ri - e

son, Ky - ri

Ky - ri - e, vi - son.

Ky - ri - e - i - son.

IV

son, e - le - i - son, e - le - i - son.

son, e - le - i - son, e - le - i - son.

ri - e, Ky - ri - e e - le - i - son.

son, Ky - ri - e e - le -

3 6 5 4

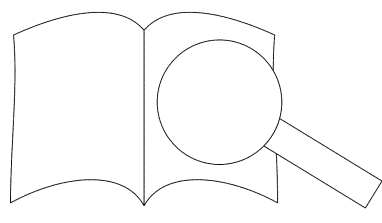

PROBENFÜR  
 Ausgabqualität gegenüber Original evtl. gemindert • Evaluation Copy - Quality may be reduced • Carus-Verlag

# 4. Gloria in excelsis Deo

Soprano 1 *Solo*  
Glo - ri - a in ex - cel - sis De - o.

Soprano 2 *Solo*  
Glo - ri - a in ex - cel - sis De - o.

Soprano 3 *Solo*  
Glo - ri - a in ex - cel - sis De - o.

# 5. Et in terra pax

Coro I  
Canto *Solo*  
Et in ter - ra pax, et *Solo*

Alto  
Et in ter - ra pax,

Tenore  
Et in ter - ra pax,

Basso  
Et in ter - ra pax,

Coro II  
Canto  
Et in ter - ra pax,

Alto  
Et in ter - ra

Tenore  
Et in ter - ra

Basso  
Et in ter - ra

Coro III  
Canto  
Et in ter - ra pax,

Alto  
Et in ter - ra pax,

Tenore  
Et in ter - ra pax,

Basso  
Et in ter - ra pax,

Caro  
Et in ter - ra pax, et in ter - ra pax,

Organo  
Et in ter - ra pax, et in ter - ra pax,

t.s. *p*

7

I

pax ho - mi - ni - bus bo - nae vo - lun - ta - tis,

pax, pax, pax ho - mi - ni - bus bo - nae vo - lun - ta - tis,

Solo Tutti

ho - mi - ni - bus bo - nae vo - lun - ta - tis, bo - nae, bo - nae vo - lun - ta - tis,

*p* Solo Tutti

pax, pax, pax, pax, et

II

in

in

et in

III

et in

et in

IV

Et in

et in

*p*

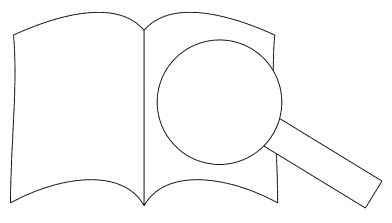

PROBENPARTITUR

Ausgabequalität gegenüber Original evtl. gemindert • Evaluation Copy - Quality may be reduced • Carus-Verlag

**I**

Tutti

pax, pax,

Tutti

pax, pax,

8 ter - ra pax, pax, pax, in ter - ra pax,

ter - ra pax, et in ter - ra

**II**

pax, in ter - ra pax, et in ter - ra pax, in ter - pa.

ter - ra pax,

ter - ra pax, et in ter - ra pax, in r.

ter - ra pax, pax,

**III**

Et in ter - ra pax, pax, in ter - ra pax,

pax, in ter - ra pax,

ter - ra pax, et in ter - ra pax,

ter - ra, et in ter - ra, et in ter - ra pax,

**IV**

ter - pax, in

pax, in ter - et in t

8 6 3 7 6 7 6 7 3

3 4 3 7 5 5 7 3

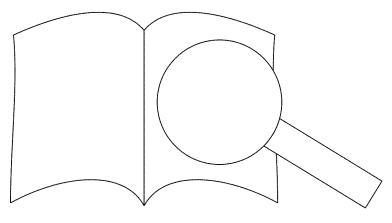



I

et in ter - ra pax, et in ter - ra  
in ter - - ra pax, et in ter - ra  
et in ter - ra pax, et in ter  
et in ter - ra pax, et in ter - ra pax

II

pax, et in ter  
pax, et ra  
pax,  
et in ter - ra pax, et in ter

III

pax,  
pax,  
et in ter - ra pax,  
et in ter - ra pax,  
et in ter - ra pax,  
et in ter - ra pax,

IV

ter  
i, i  
ra pax, in ter - ra pax,  
ra pax, in ter - ra pax,  
ter - ra pax, et in ter - ra pax, et in ter

6 6 9 8 7 7 unis. 7

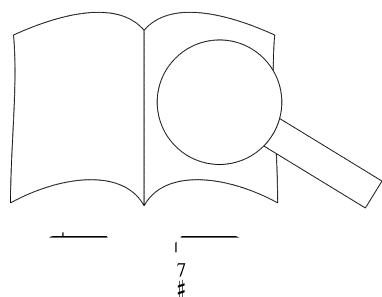

PROBENUR  
Ausgabequalität gegenüber Original evtl. gemindert • Evaluation Copy - Quality may be reduced • Carus-Verlag

I

pax, \_\_\_\_\_ in ter - - - - - ra

pax, \_\_\_\_\_ pax, in ter - ra pax, in ter - - - - - ra

pax, \_\_\_\_\_ pax, in ter - ra pax, in ter - r

pax, \_\_\_\_\_ pax\_ ho-mi-ni-bus bo - nae vo - lun - ta - tis,

II

pax, \_\_\_\_\_ et in ter - ra pax, et ir - er

pax, \_\_\_\_\_ et in ter - ra pax, et

pax, \_\_\_\_\_ pax, in - ra

pax, \_\_\_\_\_ pax\_ ho-mi-ni-bus bo -

III

pax, \_\_\_\_\_ in

pax, \_\_\_\_\_ pax, pax,

pax, \_\_\_\_\_ ra pax,

pax, \_\_\_\_\_ bo - nae vo - lun - ta - tis,

IV

pax, \_\_\_\_\_ in ter - ra pax,

pax, \_\_\_\_\_ pax, in ter - ra pax,

pax, \_\_\_\_\_ pax, in ter - ra pax,

pax\_ ho-mi-ni-bus bo - nae vo - lun - ta - tis,

5b 3 6 6 5 4 5 4 #

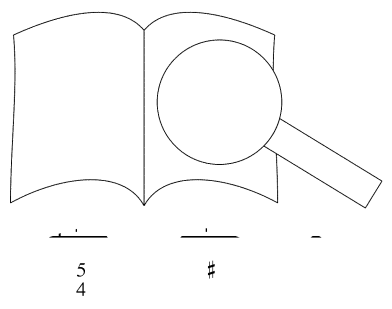

PROBEKOPPIE  
 Ausgabqualität gegenüber Original evtl. gemindert • Evaluation Copy - Quality may be reduced • Carus-Verlag

I

pax, et in ter - ra pax,  
 pax, et in ter - ra pax,  
 pax, et in ter - ra pax,  
 et in ter - ra pax

II

pax, et in ter - ra pax,  
 pax, et in ter - ra pax,  
 pax, et in ter - ra pax,  
 et in ter - ra pax

III

*pp*  
 et in ter - ra pax,  
*pp*  
 et in ter - ra pax,  
 et in ter - ra pax,  
 et in ter - ra pax

IV

*Solo*  
 et in ter - ra pax,  
*Solo*  
 et in ter - ra pax,  
 et in ter - ra pax,  
 et in ter - ra pax

7 [5#] # 6 4 5 4 # 7 2 8 3 #

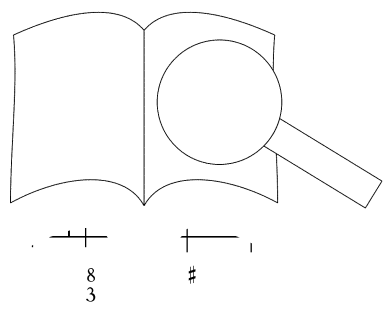

PROBENPARTITUR  
 Ausgabqualität gegenüber Original evtl. gemindert • Evaluation Copy - Quality may be reduced • Carus-Verlag

I

Solo

ho-mi - ni - bus bo - nae vo - lun - ta - tis, bo - nae, bo - nae vo - lun -

Solo *pp*

pax ho - - mi - - ni - -

Solo *pp*

pax ho - - mi - - ni

Solo *p*

pr

II

pax,

pax,

pax,

pax,

III

et in ter - ra pax,

et in ter - ra pax,

et in ter - ra pax,

et in ter - ra pax,

IV

pax,

ter - ra pax,

et in ter - ra pax,

et in ter - ra pax,

[5#]  
4 # #

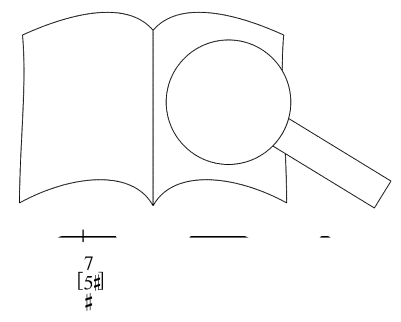

PROBENPARTITUR

Ausgabequalität gegenüber Original evtl. gemindert • Evaluation Copy - Quality may be reduced • Carus-Verlag

I

ta - - - - - tis,

bus,

bus,

pax,

II

et in

et

ter - ra

in, in ter - ra

III

in ter - ra

et in ter - ra

et in ter - ra pax, in ter - ra

et in ter - ra pax, in ter - ra

IV

Solo *p*

et

Solo *p*

Tutti

pax,

Tutti

pax,

Tutti

pax,

pax,

PROBE PARTUR

Ausgabequalität gegenüber Original evtl. gemindert • Evaluation Copy - Quality may be reduced • Carus-Verlag

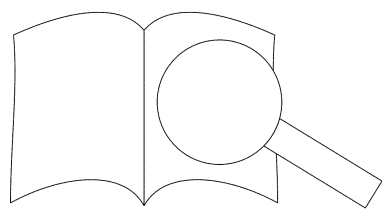

48

Tutti

I

et in ter - ra pax, in ter - ra pax,

et in ter - ra pax, in ter - ra pax,

et in ter - ra, in ter - ra pax, in ter - ra pax, in ter - ra pax, et in t

et in ter - ra, in ter - ra pax, e

II

pax, et in ter - ra

pax, et in ter

pax, pax, in ter - ra in ter - ra

pax, pax,

III

pax, ra pax,

pax, ter - ra pax,

pax, er - ra pax, in ter - ra pax,

pax,

IV

et in ter - ra pax,

et in ter - ra pax, in ter - ra pax,

et

# 6 9 8 7 # unis.

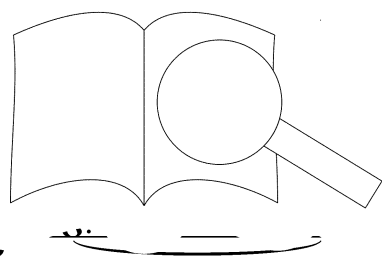

I

in ter - - - ra pax,  
 et in ter - ra pax, in ter - ra pax,  
 pax, in ter - - - ra pax,  
 in ter - - - ra pax,

II

ter - ra pax, et in ter - ra pax, et  
 et in ter - ra pax,  
 pax, et in ter - ra pax, pax, ra,  
 et in ter - ra pax, in ter - ra pax, ter - -

III

ra pax, et in ter - ra  
 in ter - ra pax,  
 et in ter - ra pax, et in ter - ra

IV

et  
 in ter - ra pax,  
 ter - - - ra  
 in ter - - - ra

7 6 6 6 9

5 5 5 5

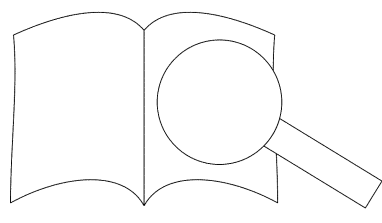

PROBEN  
 Ausgabequalität gegenüber Original evtl. gemindert • Evaluation Copy - Quality may be reduced • Carus-Verlag

I

pax, et in ter - ra pax, in ter - ra  
in ter - ra pax,  
et in ter - ra pax, in ter

II

in ter - ra  
in ter  
in ter - ra,  
- ra pax, ir

III

in ter - ra  
pax, in ter - ra pax,  
pax, - ra pax, in

IV

in ter - ra  
in ter - ra pax,  
pax, in ter  
pax, in ter

8 6 9 8 6 5b 7

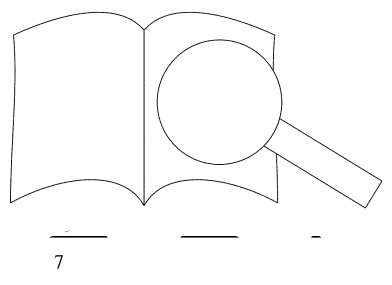

PROBEPARTITUR  
Ausgabequalität gegenüber Original evtl. gemindert • Evaluation Copy - Quality may be reduced • Carus-Verlag



I

pax, in ter - ra pax, in ter - ra pax, in ter - ra pax, in ter - ra pax, et in ter

II

pax, in ter - ra pax, in ter - ra pax, et in ter - ra

III

pax, in ter - ra pax, in ter - ra pax, et in ter - ra pax, et in ter - ra

IV

in ter - ra pax, in ter - ra pax, in ter - ra pax, in ter - ra pax, et in ter - ra pax, et in ter - ra

7 7 # unis.

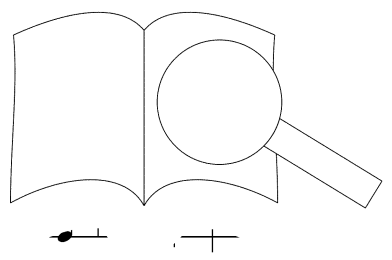

PROBEKOPPIE • Evaluation Copy - Quality may be reduced • Carus-Verlag

Ausgabequalität gegenüber Original evtl. gemindert

70

I

Solo

pax, \_\_\_\_\_

pax \_\_\_\_\_

pax \_\_\_\_\_

pax \_\_\_\_\_

et in ter - ra pax, pax

Solo

Solo

Solo

Solo *p*

pax ho - mi - ni - bus bo - nae vo - lun -

ho - mi - ni - bus bo - nae v

II

pax, \_\_\_\_\_

pax, \_\_\_\_\_

pax, \_\_\_\_\_

pax, \_\_\_\_\_

et in ter - ra pax,

et in ter - ra

III

pax, \_\_\_\_\_

pax, \_\_\_\_\_

pax, \_\_\_\_\_

pax, \_\_\_\_\_

ra pax,

ra pax,

IV

pax, \_\_\_\_\_

et in ter - ra pax,

et in ter - ra pax,

3 t.s. 3

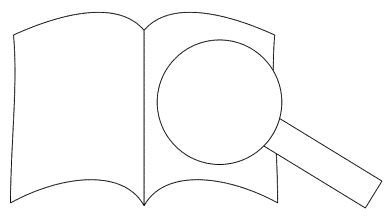

PROBEPARTITUR

Ausgabequalität gegenüber Original evtl. gemindert • Evaluation Copy - Quality may be reduced • Carus-Verlag

I

ho - mi - ni - bus bo - nae vo - lun - ta - tis,  
*p* Tutti  
 ta - tis, bo - nae vo - lun - ta - tis, bo - nae, bo -  
*p* Tutti  
 ta - tis, bo - nae vo - lun - ta - tis, bo - nae, bo -  
 Tutti  
 pax, pax ho - mi - ni - bus bo - nae vo - lun - ta

II

bo - nae,  
 bo - nae vo  
 pax, - mi - ni - bus  
 pax ho - mi - ta - tis,

III

bo -  
 bo -  
 nae, bo - nae  
 ho - mi - ni - bus bo - nae vo - lun - ta - tis,

IV

bo - nae vo - lun - ta -  
 bo - nae,  
 bo - nae  
 pax ho - mi - ni - bus bo - nae vo - lun -

3

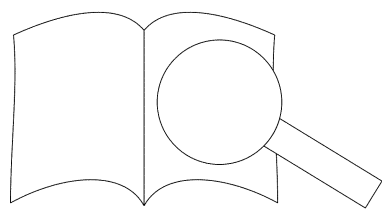

PROBENPARTITUR  
 Ausgabequalität gegenüber Original evtl. gemindert • Evaluation Copy - Quality may be reduced • Carus-Verlag

**I**

*Tutti* *pp*

bo - nae vo - lun - ta - tis, pax. \_\_\_\_\_

nae vo - lun - ta - tis, pax. \_\_\_\_\_

- - nae, bo - nae vo - lun - ta - tis, *Solo* *Tutti pp* pax. \_\_\_\_\_

vo - lun - ta - - - - - tis, pax. \_\_\_\_\_

**II**

vo - lun - ta - - - - - tis, *pp*

- - lun - ta - - - - - tis, p.

bo - nae vo - lun - ta - - - - - tis, *pp*

vo - lun - ta - - - - - tis, ..

**III**

nae vo - lun - ta pax. \_\_\_\_\_

nae vo - lun - tis, pax. \_\_\_\_\_

vo - lun - ta pax. \_\_\_\_\_

vo - lun - tis, pax. \_\_\_\_\_

**IV**

- - - - - ta - tis, *pp* pax. \_\_\_\_\_

- - - - - ta - tis, pax. \_\_\_\_\_

- lun - ta - tis, pax. \_\_\_\_\_

- - - - - ta - - - - - tis, *pp* pax. \_\_\_\_\_

6 6 5 4 4 3

PROBENPARTITUR

Ausgabequalität gegenüber Original evtl. gemindert • Evaluation Copy - Quality may be reduced • Carus-Verlag

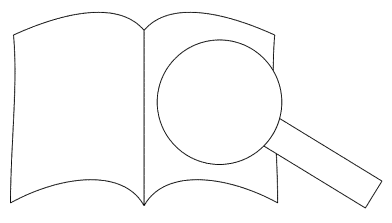

# 6. Laudamus te

Soprano concertato  
Lau - da -

Solo  
Canto Lau - da - mus te, te,  
Alto Solo Lau - da - mus te, te,  
Tenore Solo Lau - da - mus te, te,  
Basso Solo Lau - da - mus te,

Coro I

Coro II

Coro III

Coro IV

Canto  
Alto  
Tenore  
Basso

Lau-da-mus te,  
Lau-da-mus te,  
Lau-da-mus te,  
Lau-da-mus te,

O<sub>1</sub> *p* *f*



*tr* - mus, be - ne - di - ci - mus, ad - o - ra - mus, glo - ri - fi - ca - *tr* *tr* *tr*

I *p* lau - da - mus te, te, te,

*p* lau - da - mus te, *poco f* te, te,

*p* te, *poco f* lau - da - mus

*p* te, lau - da - r te,

II

III

IV *Solo p* lau - da - mus te,  
*Solo p* lau - da - mus te,  
 lau - da - mus te,

*pp*

PROBEPARTITUR  
 Ausgabequalität gegenüber Original evtl. gemindert • Evaluation Copy - Quality may be reduced • Carus-Verlag

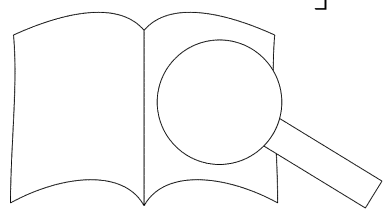

mus, lau -

**I**  
*f* Tutti  
 lau - da - mus te, lau - da - mus te, be - ne - di - ci - mus  
*f* Tutti  
 lau - da - mus te, lau - da - mus te, be - ne - di - ci - mus  
*f* Tutti  
 lau - da - mus te, lau - da - mus te, glo - ri - fi -  
*f* Tutti  
 lau - da - mus te, lau - da - mus te,

**II**  
 Lau - da - mus te, lau - da - mus te, ne - mus  
 Lau - da - mus te, lau - da - mus te, be - ci - mus  
 Lau - da - mus te, lau - da - mus te, gl - ca - mus  
 Lau - da - mus te, lau - da - m lau - da - mus

**III**  
 Lau - da - mus te, be - ne - di - ci - mus  
 Lau - da - mus te, be - ne - di - ci - mus  
 Lau - da - mus te, glo - ri - fi - ca - mus  
 Lau - da - mus - mus te, lau - da - mus

**IV**  
 lau - da - mus te, be - ne - di - ci - mus  
 lau - da - mus te, be - ne - di - ci - mus  
 lau - da - mus te, glo - ri - fi - ca - mus  
 us te, lau - da - mus te,

unis. 3 6 6 6 5 4

PROBEN  
 Ausgabqualität gegenüber Original evtl. gemindert • Evaluation Copy - Quality may be reduced • Carus-Verlag

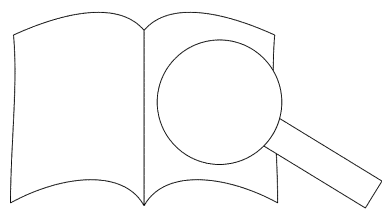

da

I

te, Solo *p* lau - da - mus te, lau - da - mus

te, Solo *p* lau - da - mus te, lau - da - mus te, lau

te, Solo *p* lau - da - mus te, lau - da - mus te,

te, Solo *p* lau - da - mus te,

II

te,

te,

te, Solo ad - o - te,

III

te,

te,

te,

IV

te,

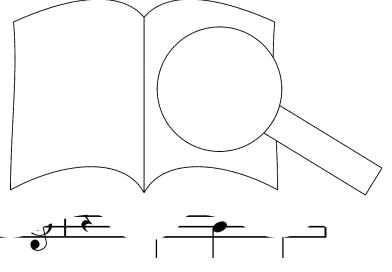

PROBE-PARTITUR

Ausgabequalität gegenüber Original evtl. gemindert • Evaluation Copy - Quality may be reduced • Carus-Verlag



mus te, lau - da - mus,

I  
te, lau - da - mus te, *f*

te, lau - da - mus te, *f* **Tutti**

lau - da - mus *f*

lau - dr

II

lau -

lau -

III

IV  
mus te,

ra - mus te,

o - ra - mus te,

*f*

PROBE PART

Ausgabequalität gegenüber Original evtl. gemindert • Evaluation Copy - Quality may be reduced • Carus-Verlag

Tutti

I

lau - da - mus, glo - ri - fi - ca - mus, lau - da -

da - mus, lau - da - mus, lau - da -

da - mus te, lau - da - mus te,

da - mus te, glo - ri - fi - ca - mus te, lau -

II

lau - da - mus, lau - da - mus da

da - mus, lau - da - mus - ne-

da - mus, la - mus,

glo - ri - fi - ca - ca - mus

III

ad - o - ra - mus, glo - ri lau - da - mus

ad - o - ra - mus, lau - da - mus te,

ad - o - ra - mus, mus, lau - da -

ad - o - ra - mus, fi - ca - mus, lau - da - mus te,

IV

ra - mus, glo - ri - fi - ca - mus, lau - da - mus

ra - mus, glo - ri - fi - ca - mus, lau - da - mus

o - ra - mus, glo - ri - fi - ca - mus, lau - da - mus

ad - o - ra - mus, glo - ri - fi - ca - mus,

3 3 6 9 8

PROBEN  
Ausgabequalität gegenüber Original evtl. gemindert • Evaluation Copy - Quality may be reduced • Carus-Verlag

I

mus,  
 mus, lau-da-mus  
 da - mus te, glo - ri - fi - ca - mus te, lau-d'

II

lau - da - mus te, glo - ri - fi - ca - mus te,  
 di - ci - mus, be - ne - di - ci - mus, glo - ri - mus  
 lau - da - mus te,  
 te, lau - da - mus te, glo - te,

III

te, lau - da - mus te, te, te, glo -  
 lau - da - mus te, te,  
 - mus te, te,  
 lau - da - mus - mus te, te,

IV

te, ce, glo - ri - fi - ca - mus  
 - mus te, glo - ri - fi - ca -  
 lau - da - mus te, glo - ri - fi - ca -  
 te, lau - da - mus te, glo - ri - fi - ca -

6 9 8 5h 6 9h 6 3 6 4

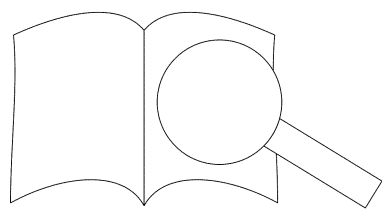

PROBEKOPPIE • Evaluation Copy - Quality may be reduced • Carus-Verlag

Ausgabequalität gegenüber Original evtl. gemindert •

glo - ri - fi - ca -

I  
be - ne - di - ci - mus te, \_\_\_\_\_ Solo

te, be - ne - di - ci - mus te, \_\_\_\_\_ Solo

te, be - ne - di - ci - mus te, \_\_\_\_\_ Solo

te, te, te, \_\_\_\_\_

II  
ri - fi - ca - - mus te, te, \_\_\_\_\_ *p*

te, lau - da - mus te, lau - da - mus te, te, \_\_\_\_\_

glo - ri - fi - ca - mus lau - da - mus te, \_\_\_\_\_

glo - ri - fi - ca - - mus te \_\_\_\_\_

III  
ri - fi - ca - - te, \_\_\_\_\_ *p*

glo - ri - fi - r - te, te, \_\_\_\_\_ *p*

lau - te, te, \_\_\_\_\_ *p*

glo - ri - f - te, te, te, \_\_\_\_\_ *p*

IV  
te, - mus te, te, te, \_\_\_\_\_ *p*

lau - da - mus te, te, te, \_\_\_\_\_ *p*

lau - da - mus te, lau - da - mus te, te, te, \_\_\_\_\_ *p*

fi - ca - - mus te, te, te, \_\_\_\_\_ *p*

te, te, te, \_\_\_\_\_ *p*

te, te, te, \_\_\_\_\_ *p*

te, te, te, \_\_\_\_\_ *p*

te, te, te, \_\_\_\_\_ *p*

7 5 4 | 9 6 5 | 4

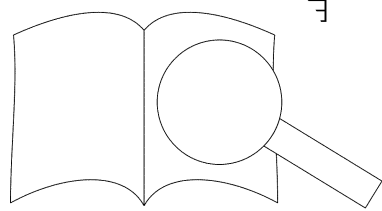
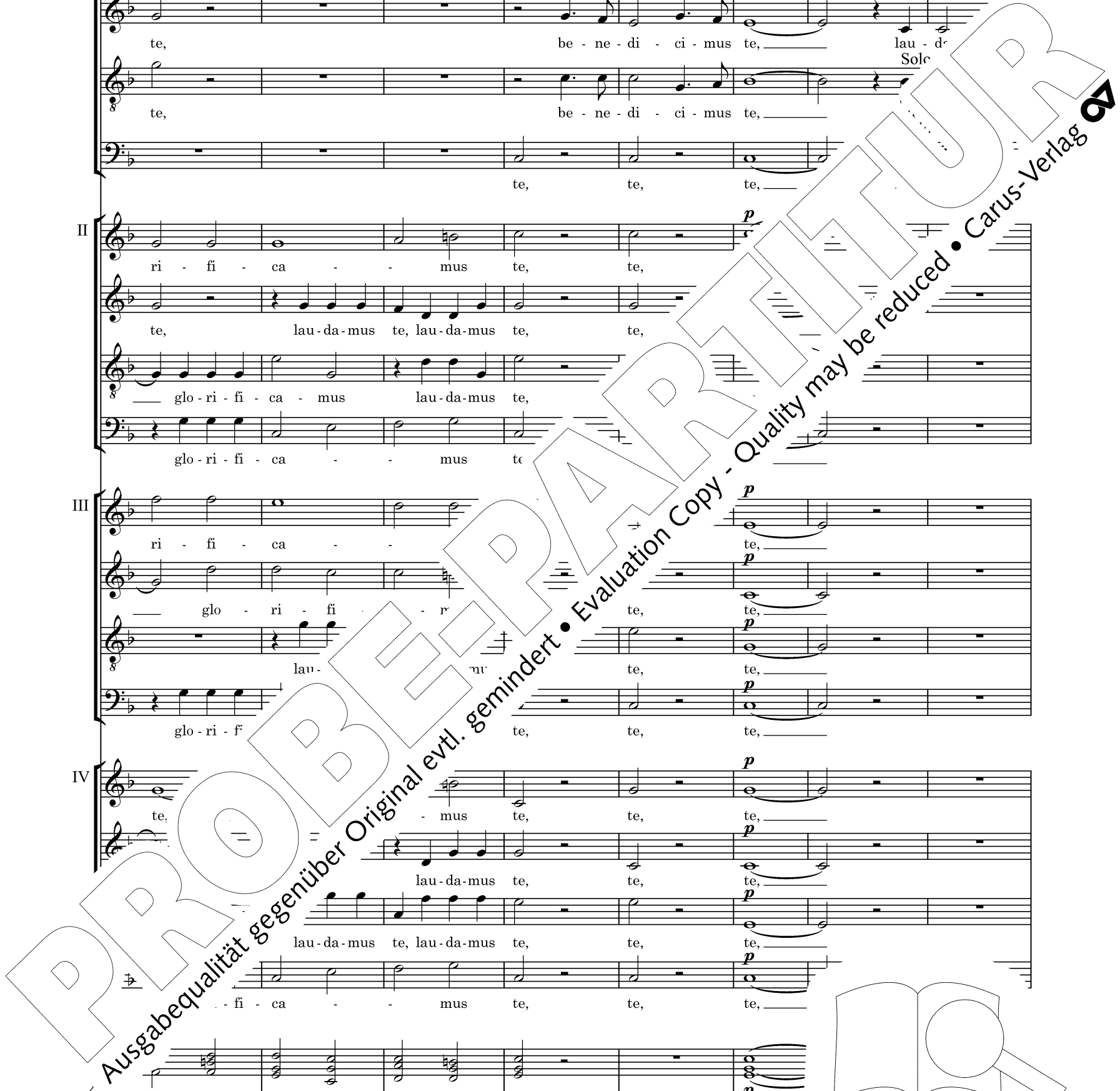

I

Tutti  
lau - da - mus te,  
Tutti  
te, lau - da - mus te,  
Tutti  
te, lau - da - mus te,  
Tutti  
te, lau - da - mus te,

II

f  
lau - da - mus te  
f  
lau - da -  
te,

III

f  
lau - da - mus  
f  
lau - da - mus  
f  
lau - da - mus  
f  
lau - da - mus

IV

- mus te,  
Solo  
te,  
f Tutti  
lau - da - mus  
f Tutti  
lau - da - mus  
f Tutti  
lau - da - mus  
f Tutti  
lau - da - mus

PROBE  
Ausgabequalität gegenüber Original evtl. gemindert • Evaluation Copy - Quality may be reduced • Carus-Verlag

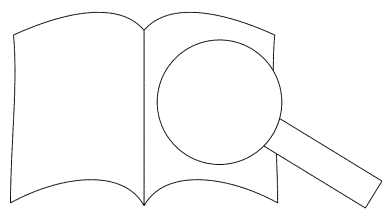

60

I

Solo *p*

te, lau - da - mus te, glo - ri - fi - ca

Solo *p*

te, lau - da - mus te, glo - ri - fi

te,

II

Solo

ad - o - ra - mus te,

III

*p*

te, te, te, te,

*p* *p* *p* *p*

te, te, ad - o - ra - mus te,

*p* *p*

te,

IV

te,

te,

*p*

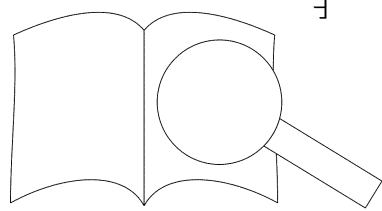

\* Siehe den Kritischen Bericht. / See the Critical Report.

6 5 6  
4 3 4

66

tr tr

I  
- mus te,

- mus te, lau - da - mus te,

Tutti Solo  
lau - da - mus te, lau - da - mus te,

II  
Solo *f*  
lau - da - mus te,

Solo *f*  
lau - da - mus te,

Solo *f*  
lau - da - mus te,

Solo *f*  
lau - da - mus te,

lau - da - mus te,

III

IV  
lau - da - mus

lau - da - mus

lau - da - mus te, lau - da - mus

lau - da - mus te,

5 6 - 3 6 7 7  
3 4 b

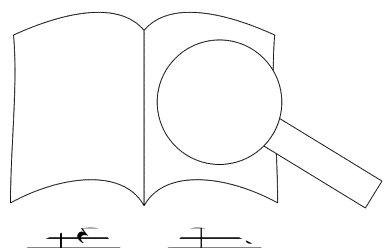

Piano introduction with trills (tr) and a fermata.

I

Solo *p*

te, te, *p* più *f*

Solo *p* più *f*

te, te, ad - o - ra

Solo *p* più *f*

te, te, ad - o - ra

Solo

ad a

II

Empty musical staves for the second part.

III

Empty musical staves for the third part.

IV

te,

Empty musical staves for the fourth part.

Empty musical staves for the fifth part.

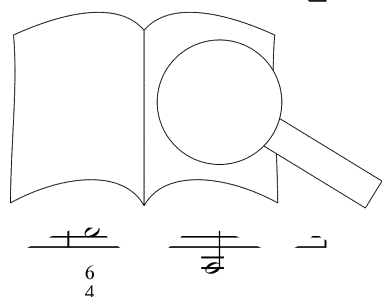

PROBE PARTITUR

Ausgabequalität gegenüber Original evtl. gemindert • Evaluation Copy - Quality may be reduced • Carus-Verlag



mus te, lau - da - mus te, lau - da - mus

**I**

Tutti lau - da - mus te, lau - da - mus

mus te, glo - ri - fi - ca

mus te,

**II**

Tutti lau - da - mus te,

te,

Tutti te,

glo - ri - fi - ca

**III**

f lau - da - mus

lau - da - mus te,

glo - ri - fi -

Tr. lau - da - mus te, lau -

**IV**

te, lau - da - mus te,

lau - da - mus te, lau - da - mus te,

lau - da - mus te, glo - ri - fi - ca

glo - ri - fi - ca

PROBE PAPIER

Ausgabequalität gegenüber Original evtl. gemindert • Evaluation Copy - Quality may be reduced • Carus-Verlag

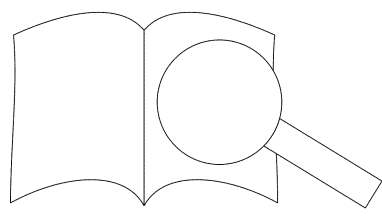

I

te, glo - ri - fi - ca - - - - -  
 - - mus te, lau - da - mus te, lau - da - mus  
 lau - da - mus te, glo - ri - fi - ca - - - - -  
 - - - - mus te, glo - ri - fi - ca - - - - -

II

te, lau - da - mus te, glo - ri - fi - ca - - - - -  
 lau - da - mus te, glo - ri - fi - ca - mus, fi - as,  
 glo - ri - fi - ca - - - - m glo - ri - fi -  
 - - - - mus te, glo - ri - fi -

III

lau - da - mus te, lau  
 ca - mus te, te,  
 da - mus te,  
 - - - - mus ca

IV

lau  
 - r glo - ri - fi - ca - mus te, glo - ri - fi -  
 glo - ri - fi - ca - mus, glo - ri - fi -  
 glo - ri - fi - ca - mus te,  
 mus te, glo - ri - fi - ca - - - - -

3 \ 64

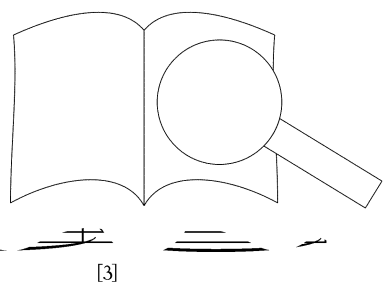

PROBEN

Ausgabequalität gegenüber Original evtl. gemindert • Evaluation Copy - Quality may be reduced • Carus-Verlag

I

mus te,  
te, lau - da - mus te,  
mus te,  
mus te, lau - da - mus te,

II

ca - mus te,  
glo - ri - fi - ca - mus te,  
ca - mus te, glo -  
mus, lau - da - n

III

te,  
ri - fi - ca - mus te,  
te, glo - ri - fi - ca - mus te,  
da - mus te,

IV

ca - mus  
ca - mus te,  
fi - ca - mus te,  
mus te, lau - da - mus te,  
mus, lau - da - mus te,

[6] [4] [7]  
[5] [4] [4]  
[4] [2]

b7 6  
5 4

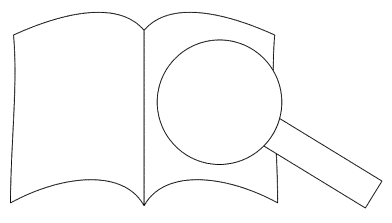

PROBENPARTITUR  
Ausgabequalität gegenüber Original evtl. gemindert • Evaluation Copy - Quality may be reduced • Carus-Verlag

I

lau-da-mus te, glo - ri - fi - ca - mus, lau - da - mus te. \_\_\_\_\_

lau-da-mus te, glo - ri - fi - ca - mus, lau - da - mus te. \_\_\_\_\_

lau-da-mus te, glo - ri - fi - ca - mus te, lau - da - mus te. \_\_\_\_\_

lau-da-mus te, glo - ri - fi - ca - mus te, lau - da - mus te. \_\_\_\_\_

II

ca - mus te, glo - ri - fi - ca - mus te, lau - da

ca - mus te, glo - ri - fi - ca - mus te, 1

mus te, glo - ri - fi - ca - mus

lau-da-mus te, glo - ri - fi - ca - mus, lau te. \_\_\_\_\_

III

glo - ri - fi - ca - da - mus te. \_\_\_\_\_

glo - ri - fi - as te, lau - da - mus te. \_\_\_\_\_

glo - te, lau - da - mus te. \_\_\_\_\_

mus te, lau - da - mus te. \_\_\_\_\_

IV

be - ne - di - ci - mus te, lau - da - mus te. \_\_\_\_\_

be - ne - di - ci - mus te, lau - da - mus te. \_\_\_\_\_

be - ne - di - ci - mus te, te. \_\_\_\_\_

glo - ri - fi - ca - mus te, lau - da - r

7 unis. 6 5 3 6 [6/4]

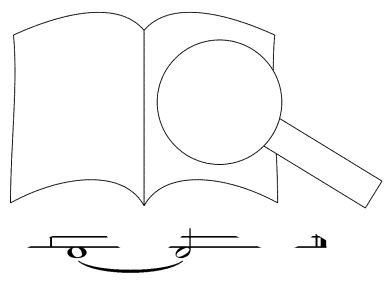

PROBEN  
Ausgabequalität gegenüber Original evtl. gemindert • Evaluation Copy - Quality may be reduced • Carus-Verlag

# 7. Gratias agimus tibi

Tenore principale

8

Solo Gra - ti - as

Canto

Solo Gra - ti - as ti - bi,

Alto

Solo Gra - ti - as a - gi-mus ti - bi,

Tenore

Solo Gra - ti - as a - gi-mus ti - bi,

Basso

Solo Gra - ti - as

Canto

Gra - ti - as ti - bi,

Alto

Gra - ti - as ti - bi,

Tenore

8

Gra - ti - as ti - bi,

Basso

Gra - ti - as ti - bi,

Organo

2 6 5

6

I

a - gi-mus ti - bi

ti - bi,

ti - bi,

ti - bi,

II-IV

pro-pter ma

pro - pter ma - gnam glo - ri - am tu - am,

pro-pter ma

pro-pter ma

8 5 6 3 - 3 [-] 3 - 3 -

8 pro - pter ma -

II-IV gnam glo - ri - am tu - am, pro - pter

pro - pter ma - gnam glo - ri - am tu - am,

8 gnam glo - ri - am tu - am,

gnam glo - ri - am tu

7 6b 5 - 7 3 6 5b 6 3

unis.

8

I Solo *pp* pro - pter ma - gnam glo - ri - am,

Solo *pp* pro - pter ma - gnam glo - ri - am,

II-IV m

am,

m tu - am,

a glo - ri - am tu - am,

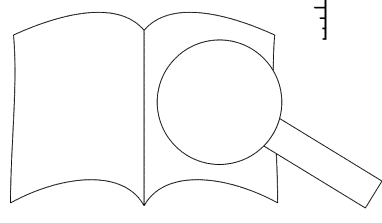

8

I

ma - gnam glo - ri-am tu - am, ma - gnam glo - ri-am tu - am,

7 6

8

I

ma - gnam glo - ri-am tu - am,

tu - am,

II-IV

ma-gnam glo - ri-am tu - am, pro-pter ma - gnam, ma - gnam

pro-pter ma - gnam, pro - pter ma - gnam

pro-pter ma

pro-pter ma

6 4 [-] 5 4 [-] 3 3 3 3 3

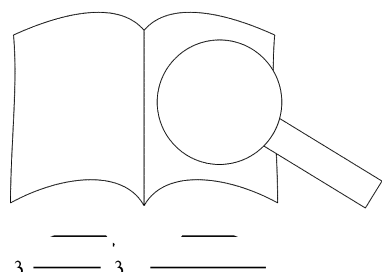

8 gra - ti - as ti - bi, pro - pter ma - - - -

II-IV glo - ri - am tu - am,

- gnam glo - ri - am tu - am, pro - pter ma - gnam

8 - gnam glo - ri - am, glo - ri - am tu - am, pro - pte

- gnam glo - ri - am tu - - - am, n.

6 9 8 6 #5[4]  
5 4

8 - - - gnam, ma - gnam glo - ri - am

I pro - pter ma - - - - gnam

Solo *pp* pro - pter ma - - - - gnam

II-IV pro - pter ma - - - - gnam

*pp* gra - ti - as ti - bi,

*pp* gra - ti - as ti - bi,

*pp*

6 5 6 7 6# 5 6b 6 7 6 [-]

PROBE PARTUR  
Ausgabequalität gegenüber Original evtl. gemindert • Evaluation Copy - Quality may be reduced • Carus-Verlag

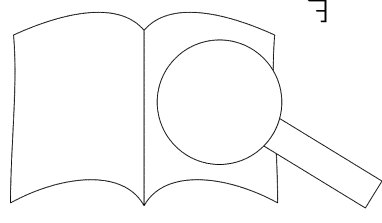



ma - gnam glo-ri-am tu - am, gra - ti - as

I Solo *p* gra - ti - as a - gi -

glo - ri - am tu - am, Solo *p* gra - ti - as a

glo - ri - am tu - am, gra - ti - as

II-IV gra - ti - as ti - bi,

gra - ti - as ti - bi,

gra - ti - as ti - bi,

gra - ti - as

ti - as a - gi - m. - pter ma -

I *pp* ti - bi, *pp* ti - bi,

ti - bi, ti - bi,

ti - bi, ti - bi,

ti - bi, ti - bi,

II-IV gra - ti - as ti - bi,

gra - ti - as ti - bi,

gra - ti -

gra - ti -

PROBENPAPIER

Ausgabequalität gegenüber Original evtl. gemindert • Evaluation Copy - Quality may be reduced • Carus-Verlag

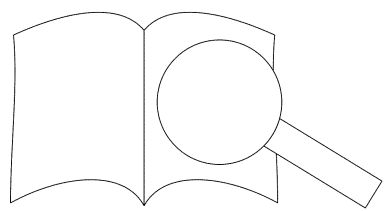

56

I

Solo *p*

gra - ti - as ti - bi,

gra - ti - as ti - bi,

Solo *p*

gra - ti - as ti - bi,

gra - ti - as

||

61

I

gra - ti - as,

pro - pter ma - gnam glo - ri - am

gra - ti - as,

pro - pter ma - gnam glo - ri - am

II-IV

pro - pter ma - gnam glo - ri - am

pro - pter

6

6

b 4# 2

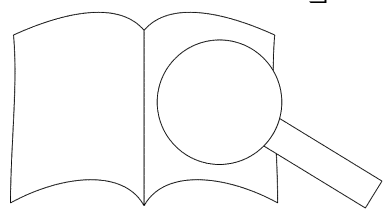

I  
 - gnam glo-ri-am tu - am, *tr*

II-IV  
 tu - am, glo - ri-am tu - am, *tr*  
 tu - am,  
 pro-pter ma-gnam glo-ri-am tu - ar  
 tu - am, *f* pro-pter ma -  
 tu - am, *f* pro-pter ma -  
 tu - am, pro - pter ma -  
 pro - pter

6 5 4 4<sup>h</sup> 6 - 3 -  
 4 2 t.s.

I  
 gra - ti - as ti - bi. *Solo*  
 gra - ti - as ti - bi. *Solo*  
 gra - ti - as ti - bi. *Solo*  
 gra - ti - as ti - bi. *Solo*  
 gra - ti - as ti - bi.

II-IV  
 - gnam glo-ri-am tu - am.  
 - gnam, pro-pter ma - gnam glo-ri-am tu - am.  
 am, pro - pter ma-gnam glo-ri-am tu - am.  
 - gnam, pro-pter ma-gnam glo-ri-am tu - am.

7 6<sup>h</sup> 6 6 5  
 4 3 4 4

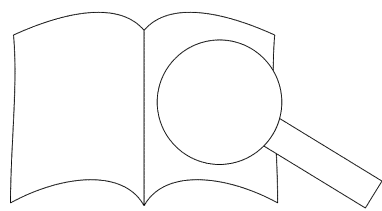

PROBEPAPIER  
 Ausgabqualität gegenüber Original evtl. gemindert • Evaluation Copy - Quality may be reduced • Carus-Verlag

# 8. Domine Deus

Coro II

Canto

Alto

Tenore

Basso

Coro III

Canto

Alto

Tenore

Basso

Solo

Do - mi - ne De - us, Rex - us Pa - ter

Solo

Do - mi - ne De - us, Rex - us Pa - ter

Solo

Do - m. ex ce - le - stis, De - us Pa - ter

Coro IV

Canto

Alto

Tenore

6 4 [ ] 5 3

6 [ 5 ] 7 4

7

II

Solo

Do - mi-ne Fi - li, Fi - li u - ni - ge - ni-te,

Solo

Do - mi-ne, Do - mi-ne Fi - li u - ni - ge - ni-te,

Solo

Do - mi - ne Fi - li u - ni - ge

III

o - mni - pot - ens.

o - mni - pot - ens.

o - mni - pot - ens.

4 7 9 8 7 5

3[4] 4 3 [5] 4

13

II

Je - su, Je - su - Chri

Je - su, ste.

Je - ste.

IV

Solo

Do - mi-ne De - us, A - gnus

Solo

Do - mi-ne De - us, A - gnus

Solo

Do - mi - ne De - us, A

6 6 7 7 6

[3] 4 4 b7

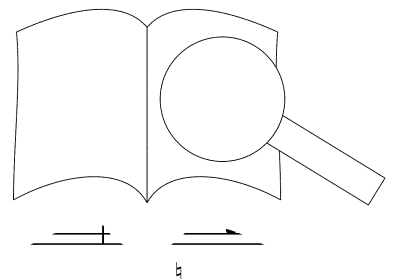

II

Qui tol - lis pec - ca - ta mun - di, qui

Solo

Qui tol - lis pec - ca - ta mun - di, qui

Qui tol - lis pec - ca - ta mun - di, qui

III

tol - lis pec - ca - ta

Qui tol - lis pec - ca - ta

IV

De - i, Fi - li - us Pa - tris.

De - i, Pa - tris.

- li - us Pa - tris.

6 6 6 6 3 3 5 3 6

4 5 4 3

3 2 [4] [3]

PROBEPARTITUR  
 Ausgabequalität gegenüber Original evtl. gemindert • Evaluation Copy - Quality may be reduced • Carus-Verlag

II

tol - lis pec - ca - ta mun - di, mi - se -

tol - lis pec - ca - ta mun - di, mi - se -

pec - ca - ta mun - di,

III

Solo

Mi - se - re - re.

mun - di, se - re - re.

ca - ta, se - re - re.

IV

se - re - re,

Solo

Mi - se - re - re,

7 5      4      4      7 4

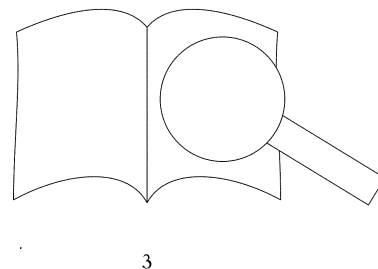

PROBE PAPIER

Ausgabequalität gegenüber Original evtl. gemindert • Evaluation Copy - Quality may be reduced • Carus-Verlag

36

II

re - re no - stri, no - - - stri.

re - re no - stri, no - - - stri.

8 re - re no - - - stri.

re - re no - stri, no - - - stri.

IV

mi - se - re - re no - - -

mi - se - re - re.

8 mi - se - re - re.

mi - se - re - re, mi tri.

9 8 6 5  
b 7 4 4

44

II

Do - mi - ne coe - le - stis, De - us Pa - ter

Do ne Rex coe - le - stis, De - us Pa - ter

mi - ne De - us, De - us, Rex coe - le - stis, De - us Pa - ter

tr

6 5 6 4 3

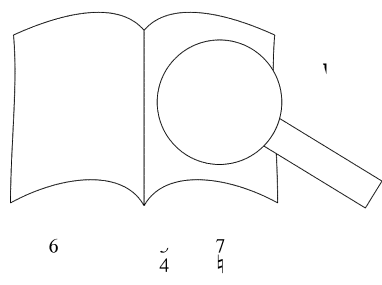



II

o - mni - pot - ens. —

o - mni - pot - ens. —

o - mni - pot - ens.

III

Do - mi - ne Fi - li,

Do - mi - ne Fi - ge - ni - te,

Do - mi - ne li u - ni - ge - ni - te,

Do - mi - ne Fi - li u - ni - ge - ni - te,

IV

A - gnus, A - gnus

Do - mi - ne De - us, A - gnus

Do - mi - ne De - us, A - gnus

Do - mi - ne De - us, A - gnus

5 7 9 8

4 4 4 3

6 4 4

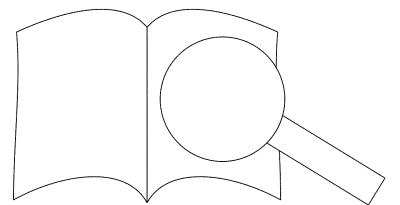

II

Qui tol - lis pec - ca - ta mun - di,

Qui tol - lis pec - ca - ta mun - di,

Qui tol - lis pec - ca - ta

Qui tol - lis pec - ca

III

Fi - li - us Pa - tris, Fi - li - us Pa - tris. lis - ta

Fi - li - us Pa - tris, Fi - li - us Pa - tris. pec - ca - ta

Fi - li - us Pa - tris, Qui tol - lis pec - ca - ta

Fi - li - us Pa - tris, Qui tol - lis pec - ca - ta

IV

De - i, Fi - li - us Pa - tris.

De - i, Fi - li - us Pa - tris.

Fi - li - us Pa - tris.

Fi - li - us, Fi - li - us Pa - tris.

5 6 6 2 6 7 9 8

[3 4] 6 2 6 7 9 8

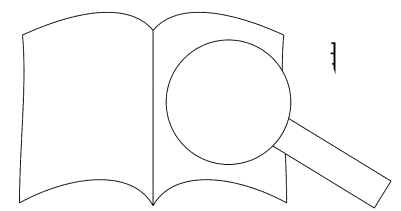

II

mi - se - re - re, mi - se - re - re.

mi - se - re - re, mi - se - re - re.

mi - se - re - re, mi - se - re - re.

mi - se - re - re, mi - se - re - re.

III

mun - di, mi - se - re - re

mun - di, mi - se - re no

mun - di, mi - se

mun - di, mi no - stri,

IV

se - re - re

mi - se - re - re

mi - se - re - re

mi - se - re - re

[54]

6 9 8 7 8

5 4b 3

2

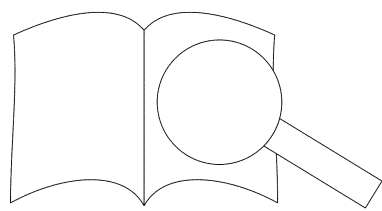

PROBEE-PARTITUR

Ausgabequalität gegenüber Original evtl. gemindert • Evaluation Copy - Quality may be reduced • Carus-Verlag

II

Qui tol - lis pec - ca - ta, pec - ca - ta mun - di, pec - ca - ta mun - di,

Qui tol - lis pec - ca - ta, qui tol - lis pec - ca - ta mun - di,

Qui tol - lis pec - ca - ta, qui tol - lis pec - ca - ta

Qui tol - lis pec - ca - ta, pec - ca

III

no - stri.

no - stri.

no - stri.

no - stri.

IV

no

no

stri.

Handwritten musical notation with figured bass:

[6]  
[4]

6 5[4] 6 6 7 6 6 5[4]

4 4 4 6

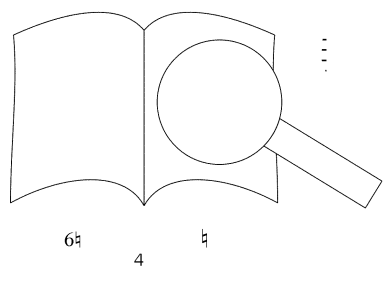

PROBEPARTITUR

Ausgabequalität gegenüber Original evtl. gemindert • Evaluation Copy - Quality may be reduced • Carus-Verlag

80

II

Tutti

sus - ci - pe de - - pre - ca - ti - o - nem,

Tutti

sus - ci - pe de - - pre - ca - ti - o - nem, de - -

Tutti

sus - ci - pe de - - pre - ca - ti - o - nem, de -

Tutti

sus - ci - pe de - - pre - - ca - - - ti

III

Tutti

Sus - ci - pe de - pre - ca

Tutti

Sus - ci - pe ca - -

Tutti

Sus - ci - pe - - nem, de - -

Tutti

Sus - ci - pe de - pre - ca - ti - o - nem,

IV

Tutti

Sus - ci - pe - - ca - - - ti - o - nem,

Tutti

Sus - - o - nem, de - pre - ca - ti -

Tutti

- pre - ca - ti - o - nem no - stram, de - pre - ca - ti -

Tutti

pe de - - pre - ca - ti - o - nem, de - pre -

b [ ]

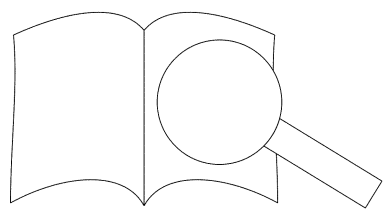

PROBE PARTITUR

Ausgabequalität gegenüber Original evtl. gemindert • Evaluation Copy - Quality may be reduced • Carus-Verlag

II

de-pre-ca-ti - o - - - - - nem no - - - - - stam. \_\_\_

- pre-ca-ti - o - - - - - nem, de-pre-ca-ti - o - - - - - nem no - - - - - stam. \_\_\_

o - - - - - nem, de-pre-ca-ti - o - - - - - nem no - - - - - stam, no - - - - - stam

nem, de-pre-ca-ti - o - - - - - nem no - - - - -

III

- pre-ca-ti - o - - - - - nem no - - - - -

- ti - o - - - - - nem, de-pre-ca-ti - o - - - - - nem no - - - - - stam. \_\_\_

- pre-ca-ti - o - - - - - nem no - - - - - stam. \_\_\_

de-pre-ca-ti - o - - - - - ne - - - - - stam. \_\_\_

IV

de-pre-ca-ti - o - - - - - no - - - - - stam.

o - - - - - nem, - o - - - - - nem no - - - - - stam, no - - - - - stam. \_\_\_

- - - - - nem no - - - - - stam. \_\_\_

- - - - - nem no - - - - - stam. \_\_\_

Handwritten musical notation with notes and rests on a staff.

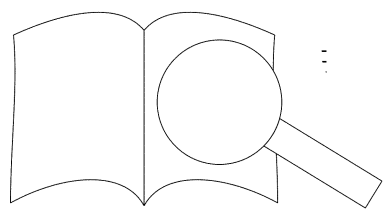

8 7 8  
5# 6 5#  
# 4 4 #

PROBE PAPIER  
Ausgabequalität gegenüber Original evtl. gemindert • Evaluation Copy - Quality may be reduced • Carus-Verlag



II

- - - tris, mi - se - re - re no - - stri. \_\_\_\_\_

- - - tris, mi - se - re - re no - - stri. \_\_\_\_\_

8 dex - te - ram Pa - tris, mi - se - re - re no - - stri. \_\_\_\_\_

- - - tris, mi - se - re - re no - -

III

dex - te - ram Pa - tris, mi - se - re - re stri \_\_\_\_\_

dex - te - ram Pa - tris, mi - se - re no ri. \_\_\_\_\_

8 - - te - ram Pa - tris, mi - - stri. \_\_\_\_\_

- - - tris, no - - stri. \_\_\_\_\_

IV

re - re no - stri. \_\_\_\_\_

- se - re - re no - stri. \_\_\_\_\_

Mi - se - re - re no - stri. \_\_\_\_\_

Mi - se - re - re no - - stri. \_\_\_\_\_

7

b7 5 3

4

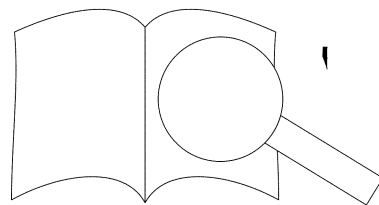

PROBEN  
Ausgabequalität gegenüber Original evtl. gemindert • Evaluation Copy - Quality may be reduced • Carus-Verlag



# 9. Quoniam tu solus Sanctus

Soprano 1  
 Soprano 2  
 Alto  
 Tenore 1  
 Tenore 2  
 Basso  
 Continuo

Quo - ni - am tu\_ so - - lus, tu so - lus\_  
 Quo - ni-am tu\_ so-lus, so - lus, tu so -  
 Quo - ni-am tu so-  
 Quo - ni - am tu\_ so - lus, so - - lus San - ctus,  
 Quo - ni - am tu\_ so - lus, so - lus San - ctus,  
 Quo - ni - am tu\_ so - lus San - ctus

6  
5

7

San - ctus, tu so - lus San - ctus  
 San - ctus. tu  
 tu\_  
 tu so - lus Do - mi - nus, tu  
 tu so - lus Do - mi - nus, tu  
 tu\_ so - lus Do - mi - nus,

tu so - lus Al - tis - si - mus,  
 tu so - lus Al - tis - si - mus,  
 tu\_ so - lus Al - tis - si - mus,

3 4 5 8 7 5 6 6 6 5 4 5 4  
 1 2 3 6 5 5 4 4 3

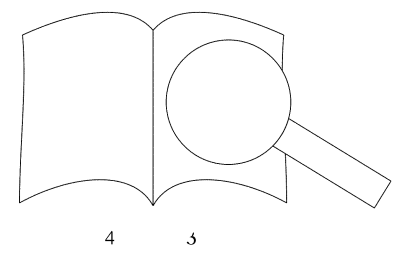

tu - so - lus San - ctus, tu

tu so - lus, tu so - lus San - ctus, tu so-lus Do - mi-nus, tu - so - lus Al-

tu so-lus San-ctus, tu so-lus Do-mi-nus

so - lus, tu so - lus, tu so-lus San-ctus, tu so-lus

so - lus, tu so - lus San - ctus, tu so-lus Do -

so - lus San - ctus, tu so-lus

b7 6 5 - 6 5  
4 3 - 4 3

so - lus, so - lus San - ctus.

tis-si-mus, San - ctus.

tu so - lus Al - tis-si-mus.

Quo - ni-am tu - so - lus

tu, tu so - lus San - ctus.

tu San - ctus.

6 6 5 4  
4 4 4 4

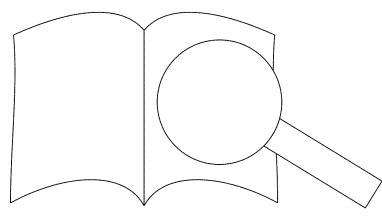

Quo - ni - am tu so - lus, tu so - lus, so - lus Do -

Quo - ni - am tu so - lus San - ctus, tu so - lus Do - mi - n

Do - mi - nus. Quo - ni -

Quo - ni - am tu so - lus, tu so - lus San - ctus,

Q' a. tu

- lus Do - mi - nr tu so - lus, tu

- mi - nr - lus San - ctus, tu so -

so - lus tu so - lus San - ctus, tu so -

so - lus Al - tis - si - mus, tu so - lus San - ctus, tu

tu so - lus Al - tis - si - mus, tu so - lus San - ctus,

so Do - mi - nus, tu so - lus San - ctus,

38

so - lus Al - tis-si-mus, tu - so - lus, tu - so -

- - lus Al - tis-si-mus, tu so - lus, tu so - lus, tu so - - lus Do - mi -

- - lus Al - tis-si-mus, tu so - lus, tu so - lus, tu - so - lus

so - lus Al - tis-si-mus, tu so - lus, tu - so - lus A'

tu so - lus Al - tis-si-mus, tu so

so - lus Al - tis-si-mus, tr I mi -

7 # 6 4 5 # 6 5 3 b7 6 6 5

44

- lus, so - - ctus.

nus, tu so - - ctus.

nus, tu - so - lu - - ctus.

so - lu - - ctus.

nus, tu so - lus San - - ctus.

- mi - nus, tu so - lus San - ctus.

tu so - lus, so - lus San - - ctus, tu.

7 # 6 5 9 8 - 7 6 5 4 # 6 6

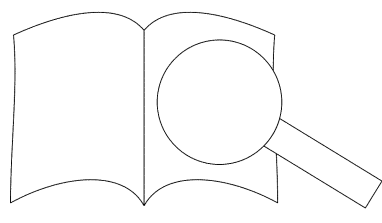

Quo - ni-am tu\_ so - lus, so -

Quo - ni-am tu\_ so - lus, tu\_ so - lus\_ San - ctus, tu

Quo - ni - am tu\_ so - lus San - ctus, quo - ni - am tu so -

Quo - ni - am tu\_ so - lus San - ctus, quo - ni -

Quo - ni - am tu so - lus, tu so - lus, tu so - lus\_ San - ctus,

Quo - ni - am tu so - lus San - ctus, tu

6 7 8 7 7 8 2 6 6# 4 4 6 5 4 2 3 3

- lus, tu so - lus\_ San - ctus, tu so - lus\_ Do - mi - nus,

so - lus, tu so - lus\_ as, tu so - lus\_ Do - mi - nus, tu so - lus\_

San - ctus, tu so - lus\_

so tu so - lus, so -

so San - ctus, tu so - - lus Do - mi - nus,

6# 5 8 9 8 7 6 5 4 3 4 3 6 7 6 5 4 3

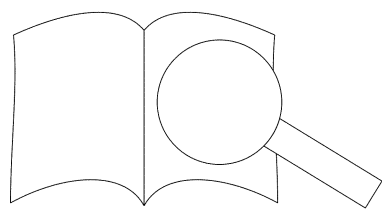

63

tu so - lus, so - - - - - lus Al - tis - si - mus, Je - su,

San - - - ctus, so - - - lus, so - - - lus Al - tis - si - mus, Je - su,

San - - - ctus, so - - - lus, tu so - - - lus Al - tis - si - mu

- - - - - lus, so - - - lus Al - tis -

tu so - lus, so - - - - - lus Al - ti

tu so - lus, so - - - lus Al - tis - Je - su,

6 5b b 3 6 5

70

Je - su Chri - ste. Je - - - - - ste.

Je - su Chri - - - - - su Chri - ste.

Je - su C - - - - - su Chri - ste. Je - su Chri - ste.

Je - - - - - su Chri - ste. Je - su Chri - ste.

ste. Je - - - - - su Chri - ste. Je - su Chri - ste.

ste. Je - - - - - su Chri - ste. Je

*p* *p* *p* *p* *p*

5# 7 6 5# 6 4 b6 7 6 7 4 3

## 2

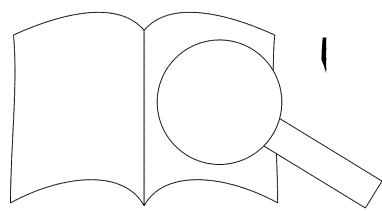

\* Siehe den Kritischen Bericht. / See the Critical Report.

# 10. Cum Sancto Spiritu

Coro I

Canto

Alto

Tenore

Basso

Coro II

Canto

Alto

Tenore

Basso

Coro III

Canto

Alto

Tenore

Basso

Coro IV

Canto

Alto

Tenore

Basso

Cum San - cto Spi - ri - tu, in glo - ri - a

Cum San - cto Spi - ri - tu, in glo - ri - a

Cum San - cto Spi - ri - tu, in glo - ri - a

San - cto Spi - ri - tu, in glo - ri - a

C. 

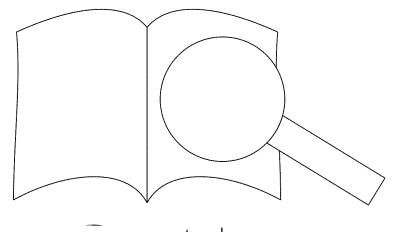

6

I

II

III

IV

glo - ri - a De - i, De - i Pa - tris, glo - ri - a

Cum San - cto Spi - ri - tu, in glo - ri - a

Cum San - cto Spi - ri - tu, in glo - ri - a

Cum Sar - ri - a De - i, De - i Pa - tris, glo - ri - a

glo - ri - a

De - i, De - i Pa - tris,

2 6 — 6 6 3 # 6

7 6 6

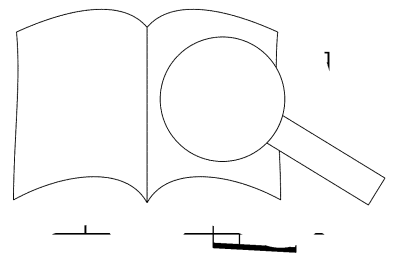



I

Cum San - cto Spi - ri - tu, in glo - ri - a,

Cum San - cto Spi - ri - tu, in glo - ri - a,

Cum San - cto Spi - ri - tu, in glo - ri - a,

II

Spi - ri - tu, in glo - ri - a De - i, De - i,

Cum San - cto Spi - ri - tu, in glo - ri - a De - i, De - i,

De - i, De - i, De - i,

glo - ri - a De - i, De - i,

III

- i, De - i Pa - tris,

De - i Pa - tris,

De - i Pa - tris,

- i, De - i

IV

Pa - tris,

Pa - tris,

in glo - ri - a

5 6 2 7 5 5<sup>♯</sup> 3 3 \ 6 6 7 #

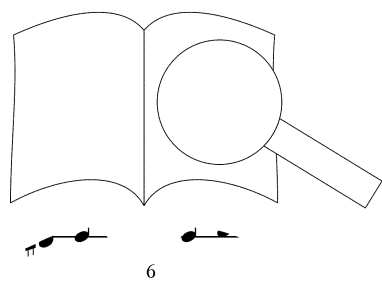

PROBENPAPIER  
 Ausgabqualität gegenüber Original evtl. gemindert • Evaluation Copy - Quality may be reduced • Carus-Verlag

I

Spi - ri - tu, in glo - ri - a De - i Pa - tris, in glo - ri - a De - i Pa -  
 glo - ri - a De - i, in glo - ri - a Pa - tris, De - i Pa -  
 glo - ri - a De - i, in glo - ri - a Pa - tris, De - i Pa - tris,  
 glo

II

glo - ri - a De - i, in glo - ri - a Pa - tris, De  
 glo - ri - a De - i, in glo - ri - a Pa - tris,  
 glo - ri - a De - i, in glo - ri - a Pa - tris,  
 Pa - tris.

III

in glo - ri - a De - i, De - i Pa - tris.  
 in glo - ri - a De - i, Pa - tris, De - i Pa - tris.  
 in glo - ri - a De - ri - a Pa - tris, De - i Pa - tris.  
 glo - ri - a in glo - ri - a Pa - tris, De - i Pa - tris.

IV

glo - ri - a Pa - tris, in glo - ri - a Pa - tris.  
 De - i Pa - tris, in glo - ri - a Pa - tris.  
 Pa - tris, glo - ri - a De - i Pa - tris.  
 Pa - tris, glo - ri - a De - i

3 6 \ 6 3 6 6 2 6 6 \ 6 5

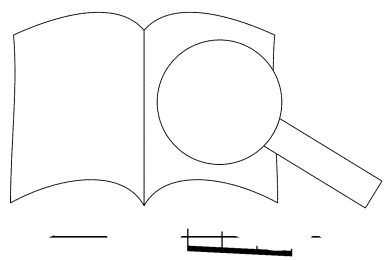

PROBEN  
 Ausgabqualität gegenüber Original evtl. gemindert • Evaluation Copy - Quality may be reduced • Carus-Verlag

22

I

in glo-ri-a De-i, in glo-ri-a Pa-tris, in glo-ri-a Pa-tris, in glo-ri-a De-i

De-i, in glo-ri-a Pa-tris,

5 4 b 5 4 3 5 4 6 6b 5 6b 5 9 6

28

I

- tris, in glo-ri-a De-i, in glo-ri-a De-i, in glo-ri-a De-i

tris, in glo-ri-a De-i, in glo-ri-a De-i, in glo-ri-a De-i

in glo-ri-a De-i, in glo-ri-a De-i, in glo-ri-a De-i

II

III

A - - - - In

A - - - -

9 3 \ 6 7 b7 b7 7 5b 6 5 4

PROBENPAPIER  
 Ausgabequalität gegenüber Original evtl. gemindert • Evaluation Copy - Quality may be reduced • Carus-Verlag

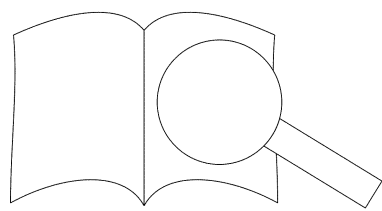

I

Pa - tris.

II

men,  
glo - ri - a De - i Pa tris,  
Cum San - cto Spi - ri - tu, in glo

III

men.

IV

6 6 6 7 7  
5 3

8	7
4	-
2	-

PROBEPARTITUR  
Ausgabequalität gegenüber Original evtl. gemindert • Evaluation Copy - Quality may be reduced • Carus-Verlag

I

men.

II

in glo - ri - a De - i, De - i Pa - tris,  
 Pa - tris, in glo - ri - a De - i, De - i Pa  
 ri - a De - i;  
 ri - a De - i - tris

III

cto Spi - ri - tu, in glo  
 In glo  
 In glo

IV

A men, in glo - ri - a Pa - tris,  
 A men,

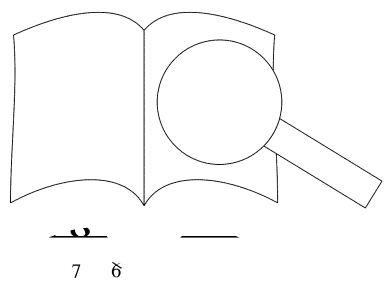

PROBENFÜR  
 Ausgabqualität gegenüber Original evtl. gemindert • Evaluation Copy - Quality may be reduced • Carus-Verlag

I

II

III

ri - a De - i, in glo - ri - a a - men, a - men, i, in glo - ri - a

IV

A

7 6 7 6 # 6 # 3

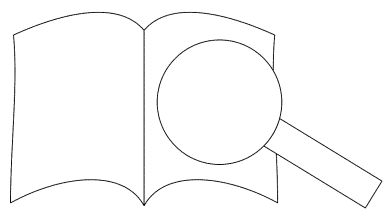

PROBENPARTITUR  
 Ausgabqualität gegenüber Original evtl. gemindert • Evaluation Copy - Quality may be reduced • Carus-Verlag

I

In glo - ri - a Pa - tris, a - - - -  
 A - - - - men, in glo - ri - a De - - - -  
 A - - - - - - - - - - mer  
 A - - - - - - - - - -

II

cum San - cto Spi - ri - tu,  
 cum San - cto Spi - ri - tu,  
 cum San - cto Spi - ri - tu,  
 cum San - cto Spi - ri - tu,

III

Pa - tris, in glo - ri - a De - - - -  
 a - men, a - - - - me.  
 Pa - tris, in glo - - - -  
 cum San - cto Spi - ri - tu,  
 cum San - cto Spi - ri - tu,  
 cum San - cto Spi - ri - tu,

IV

Cum San - cto Spi - ri - tu,  
 cum San - cto Spi - ri - tu,  
 men,

6 7

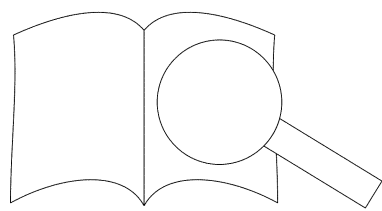

PROBEPARTITUR  
 Ausgabqualität gegenüber Original evtl. gemindert • Evaluation Copy - Quality may be reduced • Carus-Verlag

I

- - - - - men,

- - - - - i, in glo - ri - a De - i Pa - tris,

in glo - ri - a De - i, in glo - ri - a Pa - tris,

- - - - - men, in glo - ri - a Pa - tris,

II

San - cto Spi - ri - tu, in glo - ri - a

Spi - ri - tu, in glo - ri - a

Pa - tris,

Pa - tris,

men,

III

cum San - cto a -

cum San - cto a -

glo - ri - a De - i, in glo - ri - a

IV

cum San - cto Spi - ri - tu,

spi - ri - tu, in glo - ri - a De - i, in glo - ri - a

7

5

3

[5#]

8

6

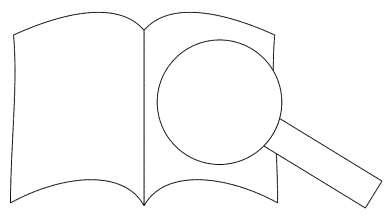

PROBEEPAARTEI  
 Ausgabqualität gegenüber Original evtl. gemindert • Evaluation Copy - Quality may be reduced • Carus-Verlag



I

II

III

IV

7 5 6 4 8 6 7 5[#] 4 # 3 0 [5#] #

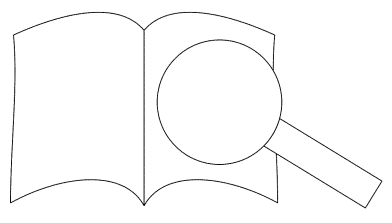

PROBENPARTITUR  
 Ausgabequalität gegenüber Original evtl. gemindert • Evaluation Copy - Quality may be reduced • Carus-Verlag

I

Pa - tris, in glo - ri - a Pa - tris, De - i

Pa - tris, in glo - ri - a Pa - tris, De - i

Pa - tris, glo - ri - a, in glo - ri - a De - i

II

in glo - ri - a Pa - tris,

in glo - ri - a Pa - tris,

De - i, glo - ri - a Pa - tris,

glo - ri - a Pa - tris,

III

De - i, in glo - ri - a Pa - tris,

Spi - ri - tu, in glo - ri - a

De - i, in

De - i

IV

a - men, a - men,

a - men, a - men,

a - men,

a - men,

a - men, a - men,

6 [5#] 64 6 9 8 2 8

5

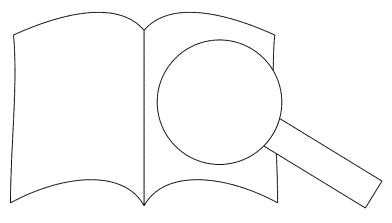

PROBEN  
Ausgabequalität gegenüber Original evtl. gemindert • Evaluation Copy - Quality may be reduced • Carus-Verlag

I

- - tris, a - - men,

Pa - tris, a - - men,

- - tris, a - - men,

Pa - tris, a - - men,

II

in glo - ri - a De - i, in glo - ri - a Pa - tris,

in glo - ri - a De - i, in glo - ri - a Pa - tris,

in glo - ri - a De - i, in glo - ri - a Pa - tris,

men, in glo - ri - a De - i, Pa - tris,

III

glo - ri - a De - i, glo - ri - a De - i,

glo - ri - a De - i, glo - ri - a De - i,

glo - ri - a De - i, glo - ri - a De - i,

glo - ri - a De - i, glo - ri - a De - i,

IV

cum ri - tu, in glo - ri - a Pa - tris,

a - - a De - i, in glo - ri - a Pa - tris,

glo - ri - a Pa - tris,

6 # 6 # 6 6b 5 6b 5

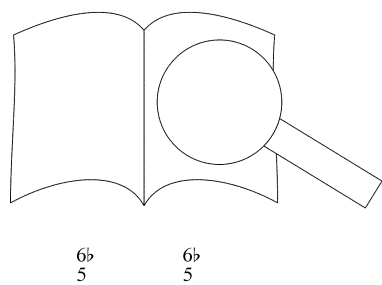

PROBENPAKUNGEN  
Ausgabequalität gegenüber Original evtl. gemindert • Evaluation Copy - Quality may be reduced • Carus-Verlag

I

glo - ri - a De - i, glo - ri - a Pa - tris, De - i

glo - ri - a De - i, glo - ri - a Pa - tris,

glo - ri - a De - i, glo - ri - a Pa - tris,

glo - ri - a De - i, glo - ri - a Pa - tris,

II

cum San - cto Spi - ri - tu, glo - ri - a

cum San - cto

in glo - ri - a

glo - ri - a

III

a - men, a - men,

a - men, cum

a - men,

a - men, in glo - ri - a

IV

a - men, in glo - ri - a De - i, in glo - ri - a,

- ri - a Pa - tris, in glo - ri - a De - i,

in glo - ri - a De - i,

9 3 6 5 b7 3 3 6 6 6 6 6 6 5 \ δ

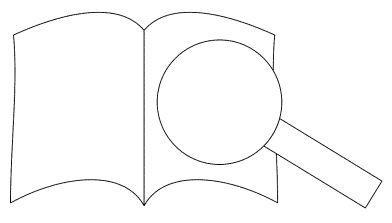

I

Pa - tris, a - men,  
 a - men, a - men,  
 a - men, a - men,  
 Pa - tris, a - men,

II

De - i, in glo - ri - a Pa - tris, in glo - ri - a De - i  
 De - i, in glo - ri - a Pa - tris, in glo - ri - a De - i  
 De - i, in glo - ri - a Pa - tris, in glo - ri - a De - i  
 De - i, in glo - ri - a Pa - tris, De - i

III

a - men, glo - ri - a De - i, De - i  
 San - cto Sp - ri - a De - i, De - i  
 in glo - ri - De tris, De - i, De - i  
 Pa - tris, in glo - ri - a De - i

IV

glo - ri - a Pa - tris,  
 glo - ri - a Pa - tris, De - i, De - i  
 glo - ri - a Pa - tris, De - i, De - i  
 De - i, glo - ri - a Pa - tris, in glo - ri - a

6 6 6 3 6 3

5 5

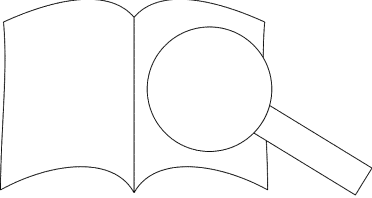

I

cum San-cto Spi - ri - tu, in glo - - ri - a Pa - tris,

cum San-cto Spi - ri - tu, in glo - ri - a De - i Pa - - tris, De - i Pa - tris,

II

Pa - tris,

Pa - tris,

Pa - tris,

Pa - tris,

III

Pa - tris,

Pa - tris,

Pa - tris,

Pa - tris,

cum San-cto Spi - ri - tu,

cum San-cto Spi - ri - tu, in

cum San-cto Spi - ri - tu, in

IV

Pa - ti

San-cto Spi - ri - tu, in glo - ri - a Pa - tris,

in glo - ri - a Pa - tris,

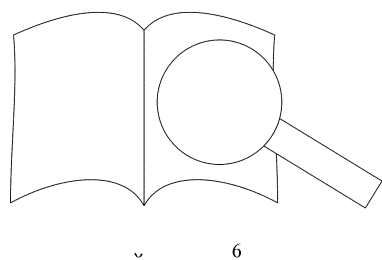

PROBEN  
Ausgabequalität gegenüber Original evtl. gemindert • Evaluation Copy - Quality may be reduced • Carus-Verlag

I

cum San-cto Spi-ri-tu,  
cum San-cto Spi-ri-tu, cum San-cto Spi-ri-tu,  
cum San-cto Spi-ri-tu,

II

a - - - - - in glo-ri-a De - - - - -  
a - - - - -  
glo - - - - - ri - - - - - ris,

III

tu, in glo - - - - - ri - a De - i,  
Spi - ri-tu, in glo - ri - a Pa - glo - ri - a De - i  
glo - ri - a De - i Pa - glo - ri - a De - i

IV

in glo - ri - a De - i Pa -  
in glo - ri - a Pa -  
in glo - ri - a Pa -  
in glo - ri - a Pa -

6 5      b7 5      6 4 3      b7 6b 4 2

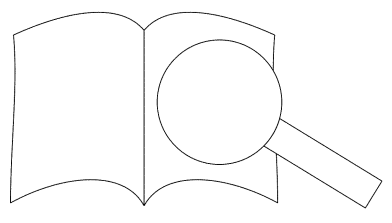

PROBENFÜR  
Ausgabequalität gegenüber Original evtl. gemindert • Evaluation Copy - Quality may be reduced • Carus-Verlag

I

cum San - cto Spi - ri - tu, cum San - cto Spi - ri - tu, in glo - ri - a

a - - - men, a - - - men, in

cum San - cto Spi - ri - tu, cum San - cto Spi - ri - tu, in

in glo - ri - a De - i, in glo - ri - a Pa - tris, cum San

II

men, in

Pa - tris, cum San - - -

men, glo - ri - a

in glo - ri - a De - i Pa - tris De - i,

III

Pa - - - tris, in glo - ri - a

tris,

tris,

IV

tris, De - - -

-is, glo - - -

in glo - ri - a, in glo - ri

8  
5  
3

3

6

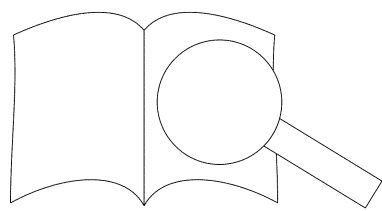

PROBENPAPIER  
Ausgabequalität gegenüber Original evtl. gemindert • Evaluation Copy - Quality may be reduced • Carus-Verlag



I

De - i Pa - tris, a - - - - -

glo - ri - a De - i Pa - tris, a - - - - -

glo - ri - a Pa - tris, a - - - - -

tu, in glo - ri - a Pa - tris, a - - - - -

*pp*

II

De - i Pa - tris, *tr*

— Spi - ri - tu,

De - i, De - i Pa - tris,

De - i Pa - tris,

III

De - i, De - i Pa - tris, a Pa - - - - -

De - i Pa - tris,

in glo - ri - a Pa - tris,

- tris, De - i Pa

*pp*

IV

i in glo - ri - a

- tris

tris, De - i Pa tris,

e Pa - tris, De - i Pa

*pp*

7 #

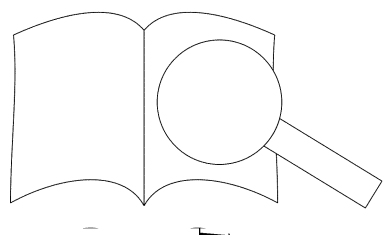

PROBENPARTITUR

Ausgabequalität gegenüber Original evtl. gemindert • Evaluation Copy - Quality may be reduced • Carus-Verlag

I

men, in glo - ri - a Pa - - - - -

men, in glo - ri - a Pa - - - - -

8 cum San - cto Spi - ri - tu, cum Sp

men, cum San - cto Spi - ri - tu,

II

glo - ri - a De - i Pa - - - - -

glo - ri - a De - i Pa - - - - -

8 glo - ri - a, in glo - ri - a Pa - - - - -

glo - ri - a, glo - ri - a Pa - - - - -

III

tris, in glo - ri - a

Pa - - - - - tris,

8 men, glo - ri - a

men, in glo - ri - a

IV

Pa - tris cum San - cto Spi - ri - tu, cum San - cto

tris, cum San - cto Spi - ri - tu, cum

Pa - tris, cum San - cto Spi - ri - tu,

gl. e - i Pa - tris, in glo -

6 5 7 -

PROBEN  
Ausgabequalität gegenüber Original evtl. gemindert • Evaluation Copy - Quality may be reduced • Carus-Verlag

I  
 - - - - - tris, De - i Pa - tris, a - men,  
 - tris, De - i Pa - tris, a - men,  
 Spi - ri - tu, in glo - ri - a De - i, De - i Pa - tris, in glo - ri - a De - i, in glo - ri  
 Spi - ri - tu, in glo - ri - a De - i Pa - tris, in glo - ri - a De - i, in

II  
 - - - - - tris, a  
 - tris, in glo - ri - a Pa - tris, n,  
 - tris, De - i Pa - tris, in  
 - tris De - i Pa - tr' in glo - ri - a

III  
 in glo - ri - a De - i, De a - men,  
 Pa - tris, in glo - ri - a De - i, in glo - ri - a  
 Pa tris, in glo - ri - a De - i, in glo - ri - a

IV  
 Spi - ri - tr i Pa - tris, a - men,  
 Sar in glo - ri - a Pa - tris, a - men,  
 a glo - ri - a De - i, De - i Pa - tris, in glo - ri - a De - i, in glo - ri - a  
 - a De - i, De - i Pa - tris, in glo - ri - a De .

6/4 6/5 - 6/5 - 3 6/4 3

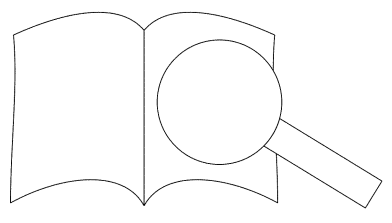

I

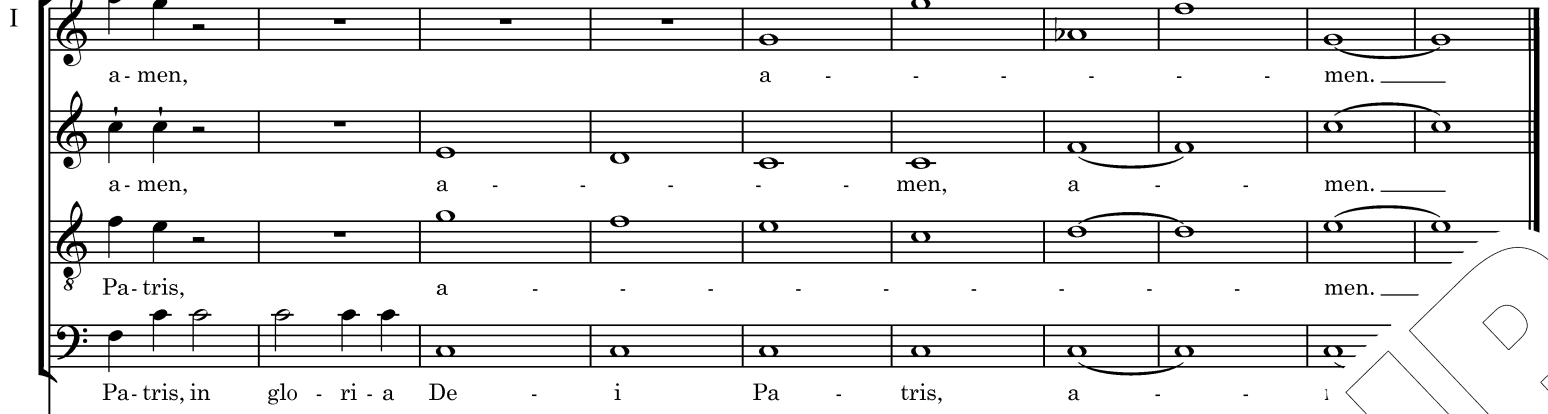

a - men, a - - - - - men.  
 a - men, a - - - - - men, a - - - - - men.  
 Pa - tris, a - - - - - men.  
 Pa - tris, in glo - ri - a De - i Pa - tris, a - - - - i

II

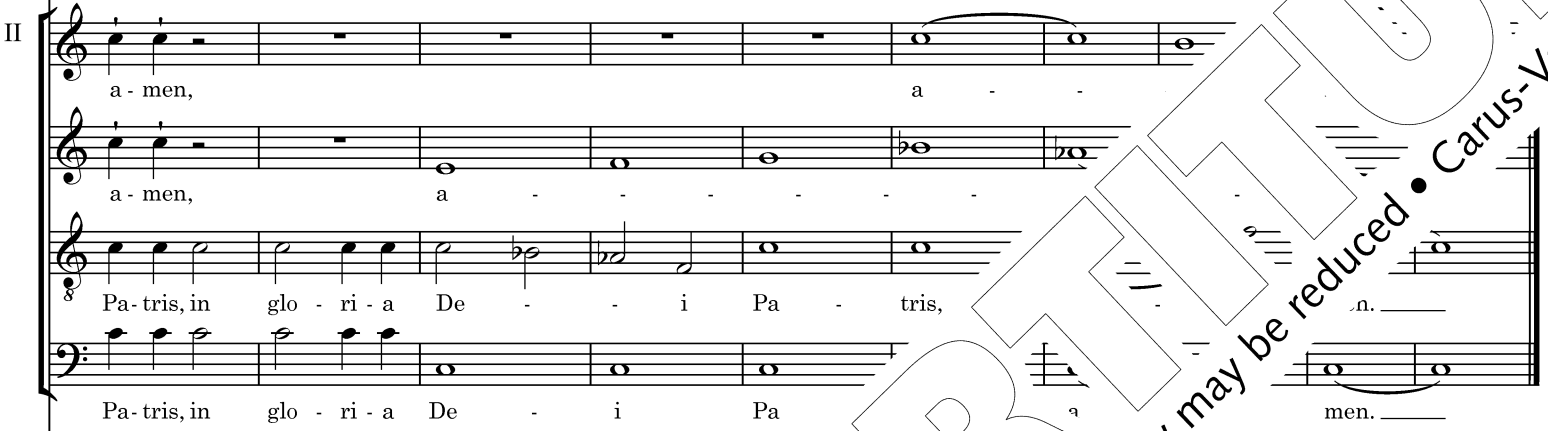

a - men, a - - - - - men.  
 a - men, a - - - - - men.  
 Pa - tris, in glo - ri - a De - - - - i Pa - tris, a - - - - - n.

III

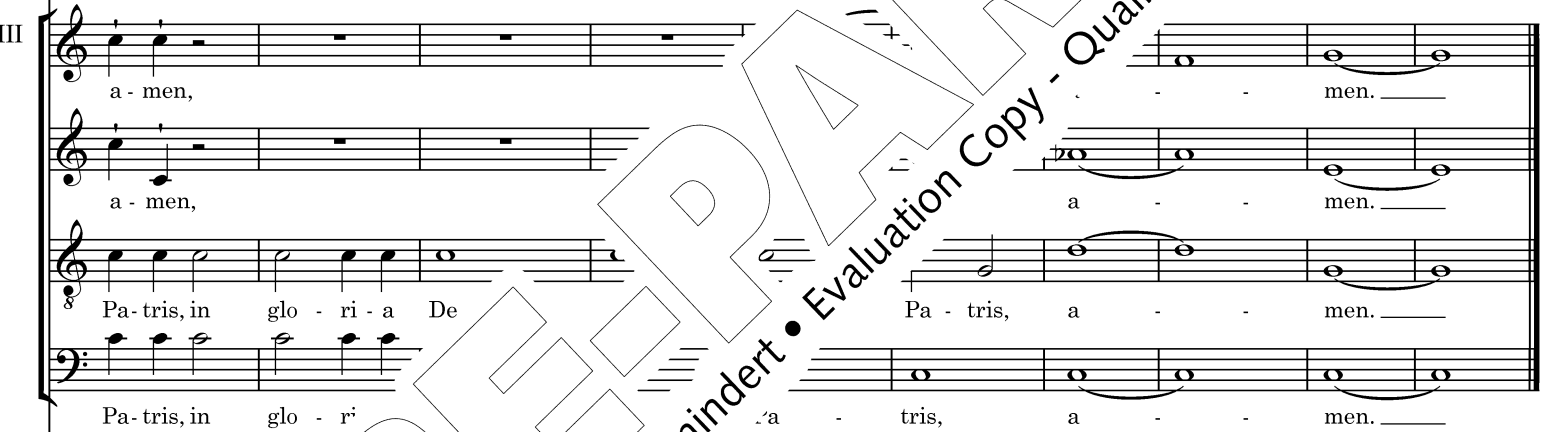

a - men, a - - - - - men.  
 a - men, a - - - - - men.  
 Pa - tris, in glo - ri - a De Pa - tris, a - - - - - men.

IV

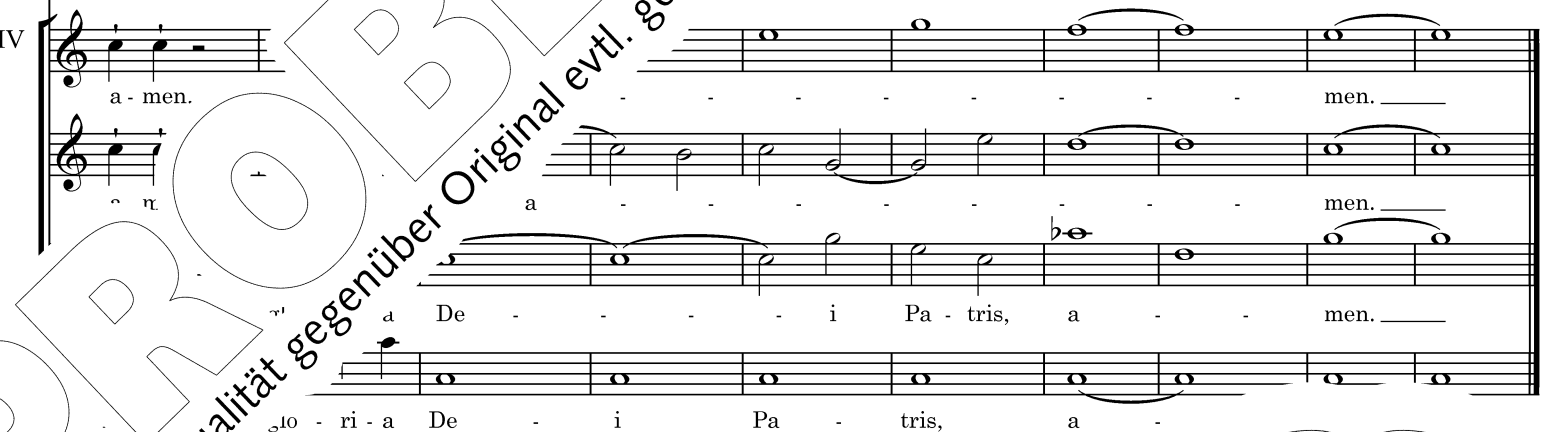

a - men. a - - - - - men.  
 a De - - - - - i Pa - tris, a - - - - - men.  
 glo - ri - a De - - - - i Pa - tris, a - - - - - men.

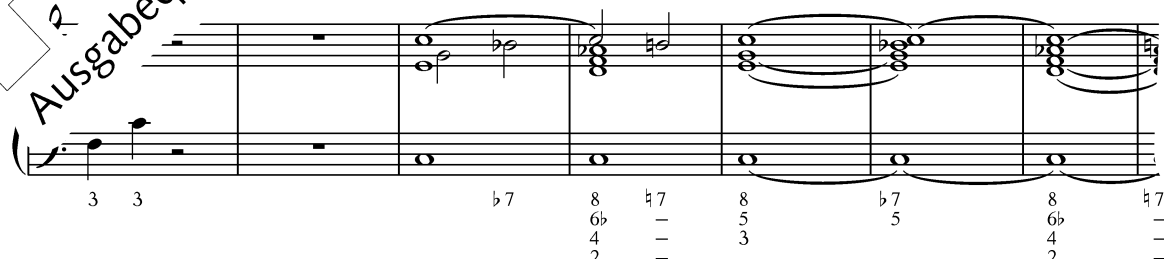

3 3                      b7                      8                      b7                      8                      8                      b7                      8                      b7

8	6b	4	2	-
5	-	-	-	-
3	-	-	-	-
5	-	-	-	-
4	-	-	-	-
2	-	-	-	-

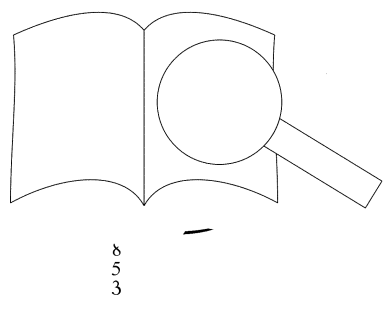

PROBENFÜR  
 Ausgabqualität gegenüber Original evtl. gemindert • Evaluation Copy - Quality may be reduced • Carus-Verlag

# Critical Report

## I. The Sources

This edition is based on the score published by Trautwein in 1839 (source **A**), copy located at University of Michigan Music Library, shelf mark *M 2013.F25 M4*.<sup>1</sup> The source for the Trautwein is unknown, as it is not completely mirrored by any extant manuscript. However, Fasch's authorship of the Trautwein is not doubted, as it represented the Sing-Akademie's performance tradition of the previous fifty years.

### Primary Source

**A:** first edition of the full score by Trautwein "SÄMMTLICHE WERKE | von | KARL CHRISTIAN FRIEDRICH FASCH. | Partitur. | SIEBENTE LIEFERUNG. | Die sechzehnstimmige Messe | nebst einem fünffachen Canon auf 25 Stimmen. | Eigenthum der Zelter'schen Erben. | Zum ausschließlichen Debit in Commission | bei | T. Trautwein, | Buch- und Musikalien Handlung in Berlin, Breite Str. N<sup>o</sup> 8. | Pr. 6 Rthlr. [...]" Second title page: "MISSA | a 16 Voci | in | Quattro Cori. | composta | da | Carlo Fasch". The score has no plate number. It includes 142 numbered pages. The Mass begins on the first numbered page; however, also published in the volume, on the page preceding 1, is Fasch's *Fünf=facher Canon auf 25 Stimmen*, scored for 3 clarinos, timpani, 3 corni, 2 flutes, 2 bassoons, 6 oboes, 2 violins, 2 violas, soprano, alto, tenor, bass (in same staff with violone, and violoncello). The Mass' title page precedes the canon.

### Other Sources

Because the Trautwein was published by the Sing-Akademie, it represents the most authoritative source. Therefore, when it was unclear or in error, the following manuscripts were consulted for insight based on their similarity to the Trautwein:

**B:** *N. Mus. SA 6*, Staatsbibliothek zu Berlin. Full copy of the Mass by unknown copyist. Titled "Missa a 16 voci in Quattro Cori composta da Carlo Fasch." Multiple handwritten dates; 1792 is written four pages preceding the title page, 1796 is written above the first and second "Kyrie" movements, 1798 above the "Et in terra pax," 1795 above the "Laudamus te," and 1798 is written above the "Cum Sancto Spiritu." "Kyrie I" meter is in common time as in the Trautwein.

**C:** *Mus.ms.5794*, Staatsbibliothek zu Berlin. Partial copy of the Mass by unknown copyist. Titled "Kyrie et Gloria a 4 Cori con Voci concertante da Carlo Fasch." Multiple handwritten dates; 1793 is written on the title page and above the second "Kyrie," "Laudamus te," "Gratias," and "Domine Deus," and 1798 is written above the "Cum Sancto Spiritu." Missing the "Quoniam" movement.

**D:** *SANT Hs 1784*, Diözesanbibliothek Münster, Santini Collection. Partial copy of the Mass by unknown copyist. Titled "Die Sechzehnstimmige Messe von Carl Fasch." Undated. Missing the second "Kyrie," "Gratias," and "Domine Deus."

Two autograph fragments remain, both versions of the "Cum Sancto Spiritu" that differ significantly from the published score. These autographs, along with a number of dissimilar manuscripts and copies, evidence Fasch's penchant for self-revision. It is difficult to identify the chronology of the extant manuscripts that predate the Trautwein.<sup>2</sup>

## II. Concerning the Edition

The present edition renders beaming and note stems, as well as the rhythmic notation of ties and the placement of accidentals and cautionary accidentals according to the principles of modern editorial practice. **A** follows an older editorial practice regarding accidentals, in which one accidental applies to all repeated notes that immediately follow, even if they occur after a bar line. This edition proceeds as follows: superfluous, repeated accidentals within the same measure have been deleted. Those accidentals whose absence according to modern practice would lead to errors, as well as accidentals for repeated notes after bar lines have been added in normal-sized print.

- Clefs and beaming are modernized. In **A**, the primary clefs used are the soprano clef for the C, S and A, the tenor clef for the T, the bass clef for the B, and the soprano, tenor and bass clef for the organ; however, occasionally **A** indicates an alternate clef to minimize using of ledger lines.
- The edition of the singing text follows the *Graduale Triplex*, Paris, Tournais 1979. Inconsistent text punctuation is streamlined.
- In **A**, most movements close with a final double bar. No. 2 "Christe eleison" elides into No. 3 "Kyrie eleison II" and thus closes with a simple double bar, as does No. 4 "Gloria." The edition uses double bar lines between Nos. 2/3 and Nos. 4/5, but final bar lines for all other movements.
- All slurs suggested by the editor are dashed, and similar text is italicized. All other articulations, accidentals, and pitches suggested by the editor use small print.
- Each movement's measures are numbered starting from 1.
- Dynamic symbols are replaced by their modern equivalents; for example, "pno" is changed to *p*.
- A consistent score order of Coro I–Coro II–Coro III–Coro IV is maintained for visual continuity (No. 2).
- In **A**, soloists were sometimes labeled with a staff title and other times by a label attached to a pitch. In this edition, soloist labels are attached to pitches and staff names are streamlined to indicate only voice type.
- In **A**, fermatas over measures with whole rests are occasionally indicated not over the whole rest, but over an "empty" portion of the measure to direct that it is to fall over a particular beat (e.g., "Gratias agimus tibi," m. 35). In this edition, those whole rests are changed into smaller rest values with fermatas indicated over the beat intended to be sustained.
- The use of trills with or without  and the position of trills (sometimes between two notes) is kept exactly as in the Trautwein printing because this rendering may have a special meaning which one cannot determine without knowledge of the engraver's copy.

<sup>1</sup> Also available in digitized form, see permanent link <http://hdl.handle.net/2027/mdp.39015070651958> or <http://digital.slub-dresden.de/werkansicht/df/67920>.

<sup>2</sup> Raymond Dittrich offers the most thorough analysis of the subject and indicates that it is unclear whether many of the handwritten dates on the manuscripts refer to their date of composition or their date of copy. See: Raymond Dittrich, *Die Fasch-Quellen in der Bischöflichen Zentralbibliothek Regensburg – zugleich ein Beitrag zur Quellenlage der 16-stimmigen Messe von Carl Fasch*, in: Carl Friedrich Christian Fasch (1736–1800) und das Berliner Musikleben seiner Zeit, Dessau 1999 (= Fasch-Studien 7), pp. 217–232.

- Inconsistent spacing and placement of Bc figures is streamlined. Figures are spaced according to beat spacing and placed below the Bc staff; however, when Bc polyphony indicates that the figure applies to the upper pitch, the figure is placed above that staff.
- Bc extension lengths are streamlined.
- The figuring “\” in No. 6 “Laudamus,” m. 82ff. and Nr. 10 “Cum Sancto Spiritu,” m. 14ff., 64, 87ff. means that the next chord is anticipated at the respective note.
- In this edition, A’s Bc pitches are indicated with full-size pitches and the pitches the editor realized from the figured bass are indicated with reduced-size pitches.

### III. Detailed Remarks

Abbreviations: A = Alto, B = Basso, Bc = Basso continuo, bt. = Beat, C = Canto, fig. = Continuo figuring, m. = Measure, Org = Organ, S = Soprano, T = Tenore.

Voice parts are abbreviated as CATB with superscript I–IV referring to their chorus placement.

#### 1. Kyrie eleison

title above first staff (page 1): “N<sup>o</sup> 1. Kyrie. a 16.”

Staff order for each movement (unless other noted) appears vertically, with brackets in front of each system, from top to bottom: “Coro I.<sup>mo</sup> | Coro II.<sup>do</sup> | Coro III.<sup>zo</sup> | Coro IV.<sup>to</sup>”. Each have horizontal additions for the respective staff: “Canto. | Alto. | Tenore. | Basso.” The last staff is “Organo.”

- |        |                                 |  |
|--------|---------------------------------|--|
| 6      | B <sup>I</sup> 2                | A: rest is missing   |
| 7      | A <sup>I</sup>                  | A: A <sup>I</sup> is the only Coro <sup>I</sup> part without an opening dynamic; dynamic <i>ff</i> added after B.  |
| 11     | A <sup>II</sup> 4–6             | A: slur ends at <i>f</i> <sup>1</sup>  |
| 13     | C <sup>IV</sup> 4               | A: repeated “Solo” remark; eliminated in the edition   |
| 17, 18 | C <sup>I</sup> , T <sup>I</sup> | A: imitative “Kyrie” figures are notated without their accompanying slurs. B slurs the m. 18 C <sup>I</sup> figure.  |
| 20     | C <sup>I</sup> 1–2              | A: dotted 8th note and 16th note are connected by notebeam and with textual underlay “lei”, perhaps because of space; first two notes in m. 21 also have a beam (which is not copied into the edition), but clear position of two separate text syllables “le-i” with hyphen; compare mm. 3 A <sup>IV</sup> +T <sup>IV</sup> , 6 B <sup>III</sup> , 29 B <sup>IV</sup> . |
| 32     | B <sup>IV</sup> 1               | A: text erroneously “-e” instead of “-son”   |

#### 2. Christe eleison

above first staff (page 11): “N 2. Christe eleison”

Different score order in this movement; staff order from top to bottom is: “Coro II<sup>do</sup> | Coro III<sup>zo</sup> | Coro I<sup>mo</sup> | Cor IV<sup>to</sup>”. The edition normalizes the score order.

In Coro<sup>I</sup>/Coro<sup>IV</sup> above first staff of each system in big letters (horizontally): “Solo=Stimmen.”; in the edition substituted by smaller “Solo” remark in each staff (m. 1, 3) for relevant voices.

- |      |   |   |
|------|---|---|
| 2, 4 | A <sup>I</sup> , T <sup>I</sup> , B <sup>IV</sup> | A indicates at other places that paired voices should have paired slurs. B and C indicate m. 4 bt. 4 A <sup>IV</sup> slurred. |
| 2, 4 | Org   | fig. added after D  |
| 3    | A <sup>IV</sup> 1                                 | A: pitch looks like <i>f</i> <sup>1</sup>   |
| 3    | Org   | A: repeated dynamic <i>p</i> ; deleted in the edition   |
| 18   | Org 3   | fig. added after B and C  |
| 19   | A <sup>I</sup> 1                                  | A has text “-lei-”; in edition reduced to “-le-” and “-i-” added in m. 22.2–3   |
| 20   | Org   | fig. “-” on bt. 2–4 added after D   |
| 25   | B <sup>IV</sup> 4–5                               | The editor suggests a slur as in m. 27, B <sup>I</sup> .  |
| 27   | C <sup>I</sup> 4–6                                | A: slur ends at <i>g</i> <sup>1</sup>   |
| 27   | T <sup>I</sup> 4–5                                | A: has “-lei-” as one syllable; in the edition adjusted to B <sup>I</sup>   |

#### 3. Kyrie eleison

above first staff (page 21): “N<sup>o</sup>3. Et in terra pax &:”

The motive ♩.♩ in m. 15 in C<sup>I</sup>+A<sup>I</sup>+T<sup>I</sup> is notated inconsistently throughout A, sometimes with slur, sometimes without, sometimes with note flags and sometimes beams, sometimes hyphenated text, sometimes without.

The edition uses flags and divided syllables for all motives, to match modern conventions and to match the notation in No. 1, m. 3 etc., but keeps slurs that are in A.

- |    |                                   |   |
|----|-----------------------------------|---|
| 11 | A <sup>I</sup> 2                  | A: beginning of tie to m. 12 is missing (before a page turn)  |
| 15 | C <sup>I</sup> , A <sup>I</sup>   | The editor suggests a slur as in m. 17, C <sup>I</sup> and A <sup>I</sup> .                                   |
| 24 | A <sup>IV</sup>                   | A: erroneous textual underlay “le-ison”   |
| 26 | C <sup>II</sup> , A <sup>II</sup> | The editor suggests a slur as in m. 17, C <sup>I</sup> and A <sup>I</sup> .                                   |
| 42 | Org 1                             | fig. added after B  |
| 43 | C <sup>IV</sup> 3                 | A: uncertain whether <i>f</i> <sup>1</sup> or <i>g</i> <sup>1</sup> , cf. A <sup>IV</sup> ; edition follows B |

#### 4. Gloria in excelsis Deo

above first staff (page 32): “N<sup>o</sup>4. Gloria &c. a tre Soprani soli”

Staff order: “Soprano I<sup>o</sup> | Soprano II<sup>o</sup> | Soprano III<sup>o</sup>”  
1, 2 remark “Solo” added, based on the original title

#### 5. Et in terra pax

above first staff (page 33): “N<sup>o</sup>5. Et in terra pax &:”

- |       |                                     |   |
|-------|-------------------------------------|---|
| 13    | Org 4–5                             | A: with slur; deleted in the edition  |
| 18    | A <sup>IV</sup>                     | Both A and B have incomplete textual underlay with the syllable “-ra” in m. 19.                     |
| 20    | C <sup>III</sup> , A <sup>III</sup> | A: beginning of tie to m. 21 and hyphen for text are missing (at the end of page)                   |
| 28    | Org                                 | fig. added after C  |
| 37–38 | Org                                 | A: fig. 4# for m. 37, bt. 3–6. A also lacks a figure extension for m. 37 bt. 2 through m. 38 bt. 1. |
| 75    | B <sup>I</sup>                      | A: beginning of tie to m. 76 and hyphen for text are missing (before a page turn)                   |
| 79    | A <sup>IV</sup>                     | A: second tie starting to m. 80 is missing (at the end of page)                                     |
| 82–83 | Org                                 | fig. added after C and D  |

#### 6. Laudamus te

above first staff (page 51): “N<sup>o</sup>6. Laudamus &:”

Staff order for first staff: “Soprano I concertato.”; further staves with staff order as in No. 1 (see above)

- |        |                                       |  |
|--------|---------------------------------------|--|
| 5      | B <sup>I</sup>                        | A, B, and C all lack a pitch for B <sup>I</sup> and include a whole rest.  |
| 30     | C <sup>conc.</sup> 3                  | A: with appoggiatura <i>e</i> <sup>2</sup> instead of <i>f</i> <sup>2</sup>  |
| 32     | Org 1                                 | A: false fig. $\frac{7}{4}$ ; edition follows B  |
| 35–45  | C <sup>conc.</sup>                    | A: an abbreviation symbol indicates for the C soloist to sing the C <sup>I</sup> staff.  |
| 38     | C <sup>II</sup> 1–2                   | A: erroneous textual underlay “(lauda)-camus”  |
| 38     | A <sup>II</sup> 1                     | A: rest is missing   |
| 43     | Org 1                                 | A: false fig. $\frac{9}{3}$ , perhaps because of space   |
| 59     | T <sup>III</sup> , B <sup>III</sup> 1 | A: superfluous remark “tutti”; eliminated in the edition   |
| 61     | C <sup>IV</sup>                       | A has a whole measure rest; C indicates a pitch, word, and dynamic as in C <sup>III</sup> ; B indicates these likewise, however, there is a slash through the pitch. The edition follows C.                            |
| 81–104 | C <sup>conc.</sup>                    | A: an abbreviation symbol indicates for the C soloist to sing the C <sup>I</sup> staff.  |
| 81, 84 | Org 7                                 | A: fig. “-” until 7th note   |
| 82     | T <sup>II</sup>                       | A: empty measure (without rest); B and C indicate a whole rest.  |
| 86–88  | Org                                   | A: only <i>c</i> <sup>0</sup> pitches, without upper voice; B and C indicate an upper voice. It is supplemented in the edition.  |
| 90     | B <sup>I</sup> 6–7                    | A: textual underlay “-mus”, but hyphens (no syllables) in m. 91, preceding new underlay “-mus” in 91.5–6; it is eliminated in the edition to match the phrasing of T <sup>I</sup> ; B and C have no syllable in m. 90. |
| 100    | Org                                   | A: false fig. $\frac{2}{3}$ on bt. 1–2; fig. corrected after B and C   |

#### 7. Gratias agimus tibi

above first staff (page 71): “N<sup>o</sup>7. Gratias &c. Tenore concertato:”

Staff order: “Tenore princip. I [vertically in front of staff 2–5:] Coro I<sup>o</sup>. I Solostimmen. I [horizontally:] Canto | Alto | Tenore | Basso | [vertically in front of staff 6–9:] Coro II<sup>o</sup> III<sup>o</sup> e IV<sup>o</sup>. I [horizontally:] Canti | Alti | Tenori | Bassi | Organo”

“Solostimmen” in front of staves in this edition have been reduced to “Solo” remarks in each staff (m. 1).

4, 16, 33, 48, 76	T <sup>princ.</sup>	<b>A:</b> each entry with remark "Solo"; they are eliminated in the edition	9	Org	<b>A:</b> beginning of tie to m. 10 is missing (at end of page)
13	Org 1	<b>A:</b> false fig. $\frac{7}{4} \flat$ ; fig. corrected after <b>B</b> and <b>C</b>	21	T <sup>I</sup>	<b>A</b> lacks singing text; in the edition text added after <b>B</b> and <b>C</b>
24	T <sup>princ.</sup>	<b>A:</b> slurs inexact, lasting 3–7 and 9–10; in edition adjusted to m. 22	38	C <sup>II</sup>	<b>A, B</b> and <b>C</b> have quarter note + quarter rest. <b>D</b> has a whole note for both C <sup>II</sup> and C <sup>III</sup> , making them match. In the edition C <sup>II</sup> adjusted to the parallel voice of C <sup>III</sup> .
27	T <sup>I</sup> 5	<b>A:</b> appoggiatura with 16th-flag; in edition adjusted to T <sup>princ.</sup>	50	C <sup>III</sup> 2	<b>A:</b> pitch looks like e <sup>2</sup>
28	T <sup>II-IV</sup>	<b>A:</b> empty measure (without rest); <b>B</b> and <b>C</b> show a whole rest.	54	Org	<b>A:</b> beginning of tie to m. 55 is missing (before page turn)
41	T <sup>I</sup> , B <sup>I</sup>	<b>A:</b> dynamic positioned between bt. 3 and 4; <b>B</b> correctly indicates the dynamic markings over bt. 3.	59	T <sup>I</sup>	<b>A</b> lacks beginning of tie to m. 60
46	B <sup>II</sup> 3	<b>A:</b> without accidental; in the edition added after <b>B</b> and <b>C</b>	60	C <sup>III</sup> 3	<b>A</b> indicates trill over the last 8th note; <b>B</b> and <b>C</b> indicate the trill over bt. 3; edition follows <b>B</b> and <b>C</b>
<b>8. Domine Deus</b>					
above first staff (page 87): "N° 8. <u>Domine Deus &amp; c.</u> "					
Staff order, vertically from top to bottom: "Coro I <sup>do</sup> Solo   Coro III <sup>zo</sup> Solo   Coro IV <sup>to</sup> Solo"; horizontally, 3x each: "Canto.   Alto.   Tenore.   Basso." The last staff is "Organo."					
"Solo" in front of system in this edition has been reduced to "Solo" remarks in each staff at their first entry.					
38	Coro <sup>II</sup> , Org	<b>A</b> indicates an accent on C <sup>II</sup> bt. 1. <b>C</b> indicates this accent in the Bc on bt. 1+2. The editor indicates similar accents in the same measure on A <sup>II</sup> and B <sup>II</sup> .	67	Org 1	<b>A:</b> fig. $\frac{7}{4}$ ; <b>B:</b> indicates $\frac{7}{4}$ . The edition follows <b>B</b> .
56	C <sup>III</sup> , A <sup>III</sup> 1–3	<b>A:</b> the slur extends only to the first 16th note. <b>B</b> indicates the slur extending to the second 16th note.	73	Org 2	<b>A:</b> fig. $\frac{6}{5}$ on beat 1; edition follows <b>B</b>
61	A <sup>II</sup>	<b>A</b> indicates the slur for the first two notes; <b>B</b> has slur for bts 1–2, all three notes. The edition follows <b>B</b> .	87	B <sup>I</sup> 4	<b>A:</b> pitch looks like b <sup>0</sup>
61	T <sup>II</sup>	<b>A:</b> indicates a slur over bt. 2–3, but a long hyphen for syllable "-ca-" below bt. 2, and places "-ta" below the third note. <b>B</b> indicates the slur over bt. 1–2. The edition follows <b>B</b> in order to adjust the long pronunciation of syllable "-ca-" as in C <sup>II</sup> , A <sup>II</sup> .	95–98	Org	<b>A</b> indicates all Bc pitches on one staff. The editor distributes between two staves to facilitate performance.
79	T <sup>II</sup>	<b>A</b> scores the final pitch as a half note on beats 2–3. <b>B</b> and <b>C</b> also have a half note. As the similar pitches in C <sup>II</sup> , A <sup>II</sup> , and B <sup>II</sup> are quarter notes followed by a rest, the editor suggests following this convention for T <sup>II</sup> .	105	A <sup>I</sup>	<b>A</b> lacks singing text; <b>B</b> and <b>C</b> indicate the text.
92	Org	<b>A:</b> with fig. "t.s."; edition follows <b>C</b>	124	Org 1	<b>A:</b> note head in small print
106	C <sup>III</sup> , B <sup>III</sup>	<b>A:</b> ending of tie from m. 105 is missing (after page turn)	126	A <sup>I</sup> 2	<b>A:</b> "-tris," missing; added from <b>B</b>
110	Org	<b>A:</b> beginning of tie to m. 111 is missing (at end of page)	126	C <sup>III</sup> , T <sup>III</sup>	<b>A:</b> beginning of tie to m. 127 is missing (before page turn)
<b>9. Quoniam tu solus Sanctus</b>					
above first staff (page 107): "N° 9. <u>Quoniam &amp; c. a 6 voci concertante.</u> "					
Staff order: "Soprano1. <sup>mo</sup>   Soprano2. <sup>do</sup>   Alto.   Tenore1. <sup>mo</sup>   Tenore2. <sup>do</sup>   Basso.   Continuo."					
15	Org 1	<b>A:</b> false fig. $\flat \frac{7}{4}$	133	T <sup>I</sup> 1–2	<b>A</b> indicates accents. However, it indicates no accents for T <sup>II-IV</sup> or B <sup>I-IV</sup> parts, which also have the singing text "amen". The editor has removed the T <sup>I</sup> accents to match this convention.
43	T <sup>I</sup> 2	<b>A:</b> pitch inexact whether c <sup>1</sup> or b <sup>0</sup> flat. It is very clearly a b <sup>0</sup> flat in <b>B</b> .	141–	Full score	<b>A</b> indicates a double-whole note to close the movement in m. 141. The edition modernizes with two tied whole notes.
60–61	Org 2	fig. added after <b>B</b> and <b>D</b>	142	Full score	<b>A:</b> behind final bar line, mid page, is "Finis."
64	A 2	<b>A:</b> text erroneously "-lus" instead of "-tus"			
66	C <sup>II</sup> 2–4	<b>A:</b> the slur extends only to the first 16th note. <b>B</b> indicates the slur extending to the second 16th note.			
68	T <sup>I</sup> 4	<b>A:</b> pitch inexact whether c <sup>1</sup> or d <sup>1</sup> ; in <b>B</b> there is definitely space above the notehead towards the line, making it look like a thrice repeated c. The editor is leaning toward the repeated c.			
69	Full score	<b>A:</b> preceding the measure (after a page turn) the measure sign c is repeated in all staves; <b>B</b> indicates c, as well at the beginning of a new page. (In <b>C</b> the movement is missing. <b>D</b> indicates no change of signature at this measure.) As the movement is nearing its close, pushing to cadence, changing to half-note values and preparing for the quite faster "Cum Sancto Spiritu," the c seems most likely.			

### 9. Quoniam tu solus Sanctus

above first staff (page 107): "N° 9. Quoniam & c. a 6 voci concertante."

Staff order: "Soprano1.<sup>mo</sup> | Soprano2.<sup>do</sup> | Alto. | Tenore1.<sup>mo</sup> | Tenore2.<sup>do</sup> | Basso. | Continuo."

15	Org 1	<b>A:</b> false fig. $\flat \frac{7}{4}$
43	T <sup>I</sup> 2	<b>A:</b> pitch inexact whether c <sup>1</sup> or b <sup>0</sup> flat. It is very clearly a b <sup>0</sup> flat in <b>B</b> .
60–61	Org 2	fig. added after <b>B</b> and <b>D</b>
64	A 2	<b>A:</b> text erroneously "-lus" instead of "-tus"
66	C <sup>II</sup> 2–4	<b>A:</b> the slur extends only to the first 16th note. <b>B</b> indicates the slur extending to the second 16th note.
68	T <sup>I</sup> 4	<b>A:</b> pitch inexact whether c <sup>1</sup> or d <sup>1</sup> ; in <b>B</b> there is definitely space above the notehead towards the line, making it look like a thrice repeated c. The editor is leaning toward the repeated c.
69	Full score	<b>A:</b> preceding the measure (after a page turn) the measure sign c is repeated in all staves; <b>B</b> indicates c, as well at the beginning of a new page. (In <b>C</b> the movement is missing. <b>D</b> indicates no change of signature at this measure.) As the movement is nearing its close, pushing to cadence, changing to half-note values and preparing for the quite faster "Cum Sancto Spiritu," the c seems most likely.

### 10. Cum Sancto Spiritu

above first staff (page 115): "N° 10. Cum sancto spiritu & c."

1–4	Org	fig. and "tasto solo" added after <b>B</b> and <b>C</b>
8	T <sup>IV</sup> 5–6	<b>A:</b> pitch inexact, $d^2/c^2 - a^1/g^1$ ; the harmonic context makes sure $d^2-g^1$ must be intended
9	C <sup>IV</sup> 3	<b>A:</b> beginning of tie to m. 10 is missing (end of page)