

Missa in Angustiis

Chorpartitur

Nelsonmesse (1798)

Kyrie

1. Kyrie eleison

Joseph Haydn
1732-1809

Allegro moderato

14 VI. I Tutti *f* 1

Soprano Ky - ri - e, - e e - lei - son,

Alto Ky - ri - e e - lei - son,

Tenore Ky - ri - e e - lei - son,

Basso Ky - ri - e e - lei - son,

14 Bassi

22 Ky - ri - e e - ri - e e - lei - son, Ky - ri - e e - lei - son,

Ky - ri - e Ky - ri - e e - lei - son, Ky - ri - e e - lei - son,

lei - son, Ky - ri - e e - lei - son, Ky - ri - e e - lei - son,

ri - e e - lei - son, Ky - ri - e e - lei - son,

4 Bassi

33 Ky - ri - e e - lei - son, son, e - lei - son, e -

Ky - ri - e e - lei - son,

Ky - ri - e e - lei - son,

Ky - ri - e

sol (Soprano II)

46 lei - son son. Chri - ste. 3

Chri -

Chri -

Chri -

1 Va. 3

ri - e e -

Ky - ri - e e - lei - son, Ky lei - son,
 Ky - ri - e Ky - ri - e e -
 lei - son, e - lei - son, Ky - son,
 Ky - ri - e e - lei - son, e - lei son, Ky - ri - e e -

Ky - ri - e e lei son,
 lei - son, ri - e e - lei - son,
 Ky - ri - e e - lei - son, e - lei son,
 lei - son, Ky

Ky - ri - e e - lei - son, Ky e son, e - lei -
 e - lei - son, Ky - ri - e lei - son, e - lei -
 lei - son, e - lei - son, e - lei -
 lei - son, e - lei - son, e - lei -

son, e - lei - son, e - lei - son e -
 son, e - lei - son, e - lei son, e - lei - son, e -
 son, e - lei - so son, e - lei - son, e -
 son, e - lei son, e - lei - son, e -

son, 2
 son, 2
 son, 2
 son, 2
 lei - son, K e e - son, e -

PROBENPARTITUR
 Original evtl. gemindert • Evaluation Copy - Quality may be reduced • Carus-Verlag

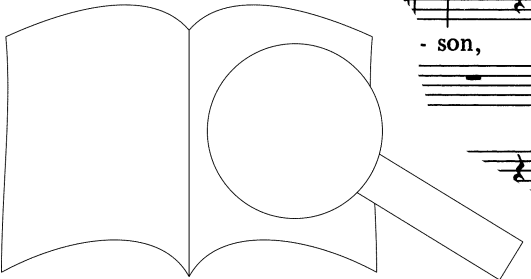

Ky - ri - e e - lei - son, Ky - ri - e e - lei - s
 Ky - ri - e e - lei - son,
 Ky - ri - e e - lei - son, n, Ky - ri - e e -
 lei - son, - ri - e e - lei - son,

Ky - ri - e e
 Ky - ri - e e - lei - son son,
 lei - son, lei
 e - le' Ky - ri - e e - lei - son, e - le' 1

son t, e - lei - son, Ky - ri - e, ri. e.
 - son, e - lei - son, Ky - ri - e -
 e - lei - son, e - lei - son, Ky - ri - e e -
 son, e - lei - son, e - lei - son, Ky - ri - e e -

lei - son, Ky - ri - e e - lei - son,
 lei - son, lei - son, Ky - ri - e e - lei - son,
 lei - son, e - lei - son, Ky - ri - e e - lei - son,
 lei - ri - e e - lei - son, Ky - ri - e e - lei - son,

son, (elei) -
 lei - son,
 e e - lei - son, Bassi -
 Ky - ri - e e - lei - son, ry - e -

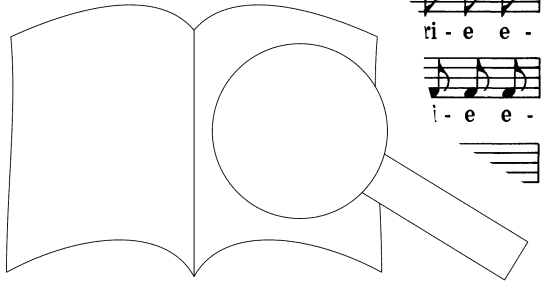

PROBEPARTITUR
 Original evtl. gemindert • Evaluation Copy - Quality may be reduced • Carus-Verlag

lei - son, Ky - ri - e e - lei - son, e - lei - son, lei - son, e -
 lei - son, Ky - ri - e e - lei - son, e - lei son, e - lei - son, e -
 Ky - ri - e e - lei - son, e - lei son, e - lei - son, e -
 Ky - ri - e e - lei - son, e - lei son, e -

fz lei - son, e - lei - son, e - son, e -
fz lei - son, e - lei - sor. son, e - lei - sor
fz lei - son, e - lei - son, e - lei -
fz lei - son, e - lei - son, e - lei -
 lei - son, e - lei - son, e - lei -

son, (elei) - ri - e e -
 Ky - ri - e e -
 ri - e, Ky - ri - e e -
 lei - son, e - lei - son, Ky - ri - e, Ky - ri - e e -

p lei - son, Ky - ri - e lei -
p lei - son, Ky - ri - e lei -
p lei - son, e - lei -
 lei - son, e - lei - son, e - lei -

son, e - lei -
 lei - son, e - lei - so
 e - lei - son, e - lei - so
 son, e - lei - son, e - lei - so

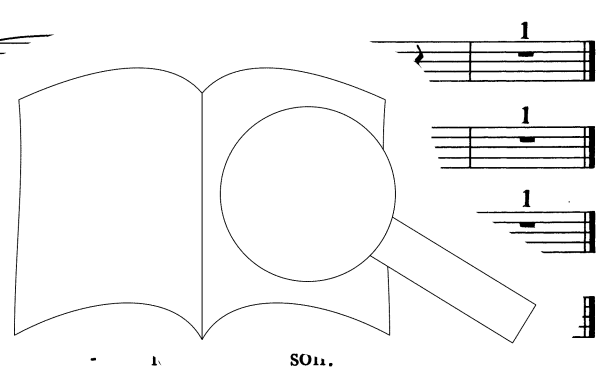

PROBENPARTITUR
 Original evtl. gemindert • Evaluation Copy - Quality may be reduced • Carus-Verlag

Gloria

2. Gloria in excelsis Deo

Allegro

Solo Tutti *f*

Glo - ri - a in ex - cel - sis De - o, glo - ri - a in ex - cel - sis De - o,
 in ex - cel - sis De - o,
 ri - a in ex - cel - sis De - o,
 Glo - ri - a in ex - cel - sis De - o,

5

glo - ri - a, glo - ri - a in ex - cel - sis De - o,
 glo - ri - a in ex - cel - sis De - o,
 glo - ri - a, glo - ri - a, glo - ri - a in ex - cel - sis De - o,
 glo - ri - a, glo - ri - a, glo - ri - a in ex - cel - sis De - o,

11

glo - ri - a, glo - ri - a in ex - cel - sis, glo - ri - a, glo - ri - a in ex - cel - sis, glo - ri - a, glo - ri - a in ex - cel - sis De - o,
 glo - ri - a, glo - ri - a in ex - cel - sis, glo - ri - a, glo - ri - a in ex - cel - sis De - o,
 glo - ri - a, glo - ri - a in ex - cel - sis De - o,
 glo - ri - a, glo - ri - a in ex - cel - sis De - o.

16

Lau - da - mus te, Lau - da - mus te, Lau - da - mus te, Lau - da - mus te.

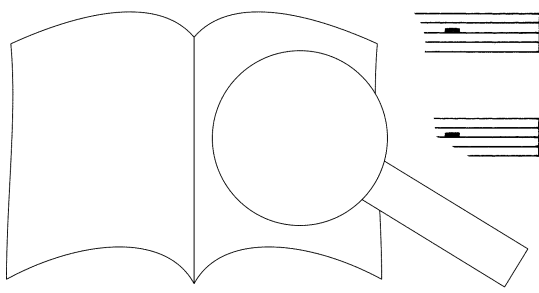

fz
 Ad-o-ra - mus te. Glo - ri - fi - mus, glo - ri - fi -
fz
 Ad-o-ra - mus te. Glo - ri - mus, glo - ri - fi -
fz
 Ad-o-ra - mus te. Glo - ri - fi -
fz
 Ad-o-ra - mus te. Glo - ri - fi -

ca - - mus te. da - mus, be - ne - di - ci-mus, ad - o -
 ca - - mus te. da - mus, be - ne - di - ci-mus, o -
 ca - - i Te lau - da - mus, te be - ne - di -
fz *fz*
 ca - Te lau - da - mus, te be -

o - ri - fi - ca - mus
 us, glo - ri - fi - ca - mus
fz
 ra - mus, te glo - ri - fi - ca - mus, glo - ri -
fz
 ra - mus, te glo - ri - fi - ca - mus, glo - ri - fi - ca - - mus

18
 te. Do - mi - ne Fi - li
 te. Do - mi - ne Fi - li
 te. Do - mi - ne Fi - li
 te. *allegro* Do - mi - ne Fi - li

Je - su Chri - ste, Je
 1 ni - te, Je - su Chri - ste, Je
 1 ni - ge - ni - te, Je - su Chri - ste, Je
 1 u - ni - ge - ni - te, Je - su Chri - ste, Je
 Je Chri

19 VI. I *f* Do - s, A - gnus
 19 Je - us, A - gnus
 19 Bassi *f* mi - ne De - us, A - gnus
 19 Jo - mi - ne De - us, A - gnus

De - i, Fi - li - us Pa - tris, Pa - tris. 1
 De - i, Fi - li - us Pa - tris, Pa - tris. 1
 De - i, Fi - li - us Pa - tris, Pa - tris.
 De - i, Fi - li - us Pa - tris, Pa - tris.

3. Qui tollis

106 Adagio

15 VI. I re - re
 15 Mi - se - re - re
 15 Mi - se - re - re
 15 e - re, mi - se - re - re

no - bis, mi re - re
 no - bis, Su - sci - pe,
 no - bis, no - bis.
 no - bis, no - bis.
 no - bis, re - re no - bis. Bassi *f p*

p no - stram, de - i
p o - nem no - stram, de - i
p a - ti - o - nem no - stram, de - i
 de - pre - ca - ti - o - nem no - stram, de - i

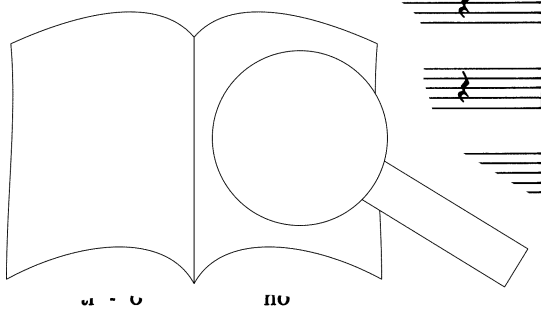

1 *f* de - pre - ca - ti - o - nem no - stram, 3
 1 *f* de - pre - ca - ti - o - nem no - stram, 3
 1 *f* de - pre - ca - ti - o - nem no - stram, 3
 1 *f* de - pre - ca - ti - o - nem r . . . n, 3

p de - pre - ca - ti - o - nem no - strar 6 *f* mi - se - re - re no - bis,
p de - pre - ca - ti - o - nem no 6 *f* mi - se - re - re no - bis,
p de - pre - ca - ti - o - nem no 6 *f* mi - se - re - re r 6
 de - pre - ca - ti stram. mi - se - re

5 no - bis, 5 *p* r.
 5 re - re no - bis, 5 se
 5 mi - se - re - re no - bis, 5 n.
 5 mi - se - re - re no - bis, 5 e
 5 mi - se - re - re no - bis, 5 re - re no - bis,

mi - se - re - re no - bis, no - bis.
 mi - se - re - re no - re - re no - bis.
 mi - se - re - re mi - se - re - re no - bis.
 mi - se - re - re mi - se - re - re no - bis. attacca

4. Quoniam

Allegro

Tutti *f*
 as, tu so - lus San - ctus, tu
 Tu
 Tu
 Tu
 Tu
 lo - mi - nus,
 o - mi - nus,
 so - so



tu so - lus Al - tis - si - mus, tu so - lus, tu
 tu so - lus Al - tis - si - mus, tu so - lus, tu
 tu so - lus Al - tis - si - mus, tu, tu so - lus, tu
 tu so - lus Al - tis - si - mus, tu, tu so - lus, tu

so - lus San - ctus, tu so - lus so - lus Al - tis - si - mus, Je - su,
 so - lus San - ctus, tu so - nus, tu so - lus Al - tis - si - mus, Je -
 so - lus San - ctus so - mi - nus, tu so - lus Al - tis - si - mus, Je
 so - lus San - ctus lus Do - mi - nus, tu so - lus Al - tis - si - mus

Je - ste. Cum San in
 Chri - ste. Cur - ri - tu, in
 su Chri - ste. Spi - ri - tu, in
 Je - su Chri - ste. cto Spi - ri - tu, in

glo - ri - a De - i Pa - tris. A - men,
 glo - ri - a De - i Pa - tris. A - men,
 glo - ri - a De - i Pa - tris. A - men,
 glo - ri - a De - i Pa - tris. A - men, in glo - ri - a De - i Pa -

in
 glo - ri - a De - i Pa - tris. A
 tris. A - men, a - a - a

f
 in glo - ri - a De - i Pa - tris. A
 tris. A - men, a - men, a - men, a -
 men, a - men, a - men, a -
 men, glo - ri - a De - i Pa - tris.

- men, in De - i Pa - tris. A - men,
 men, a - men,
 in glo - Pa - tris. A - men
 A

men,
 a - men, glo - ri - a
 men, in glo - ri - a tris. A - men,
 De - i Pa - tris. A - men, a - men,

in glo - ri - a Pa - tris. A - men, a -
 De - i Pa tris. A - men, a -
 a - men, men,
 a

men,
 men,
 in glo - ri - a De - i
 in glo - ri - a De - i A

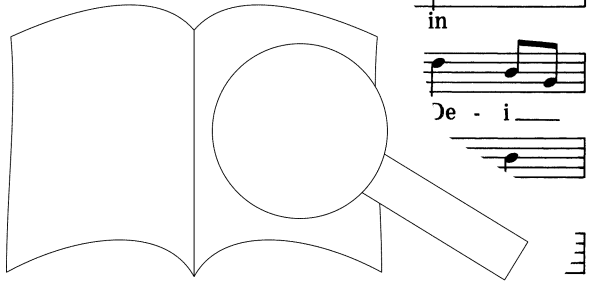

PROBENPARTITUR
 Ausgabqualität gegenüber Original evtl. gemindert • Evaluation Copy - Quality may be reduced • Carus-Verlag

glo - ri - a De - i Pa - tris. A - men, a -
 Pa - tris. A - men, a -
 in glo - ri - a De - i s. - men,
 a - men, a - men, in

men, in glo - ri - a De - i
 men, in glo - ri - a D
 a - men, in glo - r
 glo - ri - a D tris. A - men, a - men,

Pa s. A - men, a -
 a - men, a - men, a -
 tris. A - men, a
 men, a

men, a - men.
 men.
 men, a
 men, a - men, a -

men, a - men,
 men, a - men,
 men,
 men, a - men, a - men, a - men,

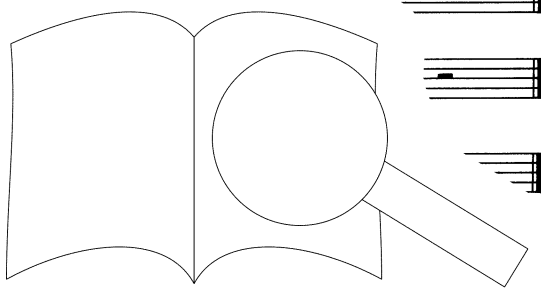

PROBEBE PARTITUR
 Ausgabqualität gegenüber Original evtl. gemindert • Evaluation Copy - Quality may be reduced • Carus-Verlag

Credo

5. Credo in unum Deum

Allegro con spirito

in canone 6

4 VI. I

Cre - do in u - num De - - um, Pa -
in u - num De - -
Cre - do in u - num De - - um, Pa -
Cre - do in u - num De - -

- - trem pot - en - tem, fa - cto - rem -
um, - trem o - mni - pot - en - cto - rem -
o - mni - pot - en - tem, fa - - li et
um, Pa - - trem o - mni - in a - cto - rem -

1, ter - rae, vi - si - bi - li - um o - mni - um, et in -
coe - li et ter - rae, - si - bi - li - um o - mni - um,
ter - rae, - bi - li - um o - mni - um, et in -
coe - li et vi - si - bi - li - um o - mni - um,

23 - um o - mni - um
vi - si - bi - li - um
si - bi - li - um o - mni -
et in - vi - si - bi - li - um

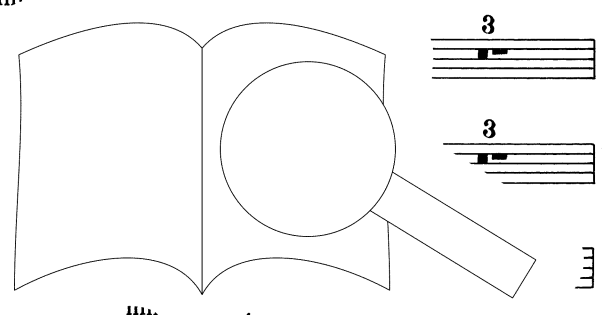

Et ex Pa-tre na-tum an o-mni-a
 Et ex Pa-tre na an-te
 Et ex Pa-tre na-tum te o-mni-a
 Et ex Pa-tre tum an-te

sae-cu-la. De e-o, lu-men de lu-mi-ne,
 o-mni-a sae-c De-um de De-o, lu-
 sae-cu-la. De-um de De-o, lu-men de
 o-mni-a - la. De-um de De-

De-um ve-rum de De-o ve-ro
 De-um ve-rum de De-
 -um ve-rum de De-o
 lu-mi-ne, De-um ve-rum. ve-ro.

Ge-ni-tum, non fa-ctum, con-sub-stan-ti-a-lem Pa-tri:
 Ge-ni-tum, non fa-ctum, con-sub-stan-ti-a-lem
 Ge-ni-tum, non fa-ctum, con-sub-stan-ti-a-lem Pa-tri:
 ni-tum, non fa-ctum, con-sub-stan-ti-a-lem

o-mni-a fa-cta sunt.
 per quem o-mni-a fa-cta
 sunt. o-mni-a fa-cta sunt.
 Pa-tri: per quem o-mni-a fa-cta

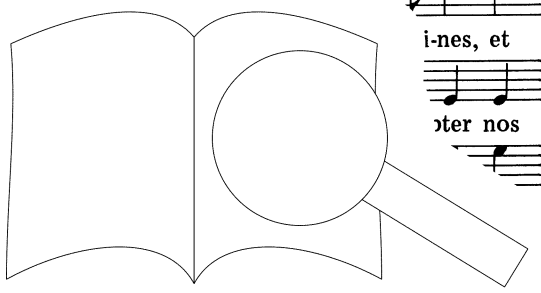

i-nes, et
 ter nos

pro - pter no - stram sa - lu - tem de - scen coe - lis, de -
 ho - mi-nes, et pro - pter no - stram sa e - scen - dit de
 pro - pter no - stram sa - lu - tem de - scen dit de coe - lis, de -
 ho - mi-nes, et pro - pter no lu - tem de - scen - dit de

scen - dit de coe - lis, de - scen dit de coe - lis,
 coe - lis, de - scen dit de coe - lis, de - scen - dit de
 scen - dit de coe - lis, de - scen - dit de coe - lis,
 coe - lis, dit de coe - lis, de - scen - dit

scen - dit de coe - lis, de - scen - dit de coe
 de - scen - dit de coe - lis, de - scen - dit de
 de - scen - dit de coe - lis, de - scen - dit de
 coe - lis, de - scen - dit de coe - lis, de -

scen - dit de coe - lis, de - scen - dit de coe - lis.
 scen - dit de coe - lis, de - scen - dit de coe - lis.
 scen - dit de coe - lis, de - scen - dit de coe - lis.
 scen - dit de coe - lis, de - scen - dit de coe - lis. attacca

6. Et incar

84 Largo

ho - mo fa - ctus Et in ri - tu -
 Et in ri - tu -
 Et in ri - tu -
 Et in ri - tu -

17 Bassi *p* Et in na - de -

San - cto ex Ma - ri - a, Ma - ri - a Vir - gi - ne: Et ho - me
 San - cto ex Ma - ri - a, Ma - ri - a Vir - gi - ne: Et
 San - cto ex Ma - ri - a, Ma - ri - a Vir - gi - ne: fa - ctus est, et
 San - cto ex Ma - ri - a, Ma - ri - a Vir - gi - no fa - ctus est, et

ho - mo fa - ctus est. Cru - ci - fi - xus et - i - am pro no - bis: sub Pon - ti - o Pi -
 ho - mo fa - ctus est. Cru - ci - fi - xus et - i - am pro no - bis: sub Pon
 ho - mo fa - ctus est. Cru - ci - fi - xus, cru - ci - fi - xus et - i - am pro no - bis: sub
 ho - mo fa - ctus est. Cru - ci - fi - xus, cru - ci - fi - xus et - i - am pro no

la - ti - o Pi - la - to, cru - ci - fi - xus et - i - am pro no - bis: sub Pon - ti - o Pi -
 Pon - ti - o Pi - la - to, cru - ci - fi - xus et - i - am pro no - bis: sub Pon - ti - o Pi -
 to, sub Pon - ti - o Pi - la - to, cru - ci - fi - xus et - i - am pro no - bis: sub Pon - ti - o Pi -
 la - to, sub Pon - ti - o Pi - la - to, cru - ci - fi - xus et - i - am pro no - bis: sub Pon - ti - o Pi -

tu - tus est, cru - ci -
 et se - pul - tus est, cru - ci -
 se - pul - tus est, cru - ci -
 et se - pul - tus est, sub Pon - ti - o Pi -

pro - no - bis, pas - sus, pa
 pro no - bis, pas - sus, pa
 pro - no - bis, pas - sus, pa
 la - to, sub Pon - ti - o Pi - la - to pa -

7. Et resurrexit

Vivace

138

Et, et re-sur-re-xi-ter-ti-a di-e, se-

Et, et re-sur-ri-ter-ti-a di-e, se-

Et re-sur-re-xi-ter-ti-a di-e, se-

Et re-sur-re-ti-a di-e, se-cun-dum Scri-

141

cun-dum Scri-ptu-ras. et a-scen-dit in coe-lum: se-det ad ram

cun-dum Scri-ptu-ras. et a-scen-dit in coe-lum: se-

cun-dum Scri-ptu-ras. et a-scen-dit in coe-lum: se-

ptu-ras. Et, et a-scen-dit in coe-lum: det: xte-ram

145

Et, et i-te-rum ven-tu-rus est cum glo-ri-a ju-di-

Pa-tris. Et, et i-te-rum ven-tu-rus est ju-di-

Pa-tris. Et, et i-te-rum ven-tu-rus est ju-di-

Pa-tris. Et, et i-te-rum ju-di-

149

ca-re vi-vos, vi-vos, et, et mor-tu-os, et

ca-re vi-vos, et mor-tu-os, et

ca-re vi-vos, et, et mor-tu-os, et

ca-r et, et, et mor-tu-os, et

154

mor-tu-os: e-gni non

et mor-tu-os:

vos et mor-tu-os:

vi-vos et mor-tu-os:

e - rit, non e - rit fi - nis, non e - rit e - rit, non
 cu - jus re - gni non e - rit, non e - rit, non e - rit, non
 fi - nis, non e - rit fi - nis, non e - rit, non e - rit, non
 cu - jus re - gni non e - rit, non e - rit, non e - rit, non

e - rit, non, non, non, e - rit fi - nis.
 e - rit, non, non, non, non e - rit fi - nis.
 e - rit, non, non, non, non e - rit fi - nis.
 e - rit, non, non, non, non e - rit fi - nis.

et in Spi - ri - tum Sa - ctum, et vi - vi - fi -
 et in Spi - ri - tum Sa - ctum, et vi - vi - fi -
 et in Spi - ri - tum Sa - ctum, et vi - vi - fi -
 et in Spi - ri - tum Sa - ctum, et vi - vi - fi -

can - tem: Qui cum Pa - tre et Fi - li - o si - mul ad - o -
 can - tem: Qui cum Pa - tre et Fi - li - o si - mul ad - o -
 can - tem: Qui cum Pa - tre et Fi - li - o si - mul ad - o -
 can - tem: Qui cum Pa - tre et Fi - li - o si - mul ad - o -

ca - tur: qui lo - cu - tus es cae - lum, et con - glo - ri - fi - ca - tur: qui lo - cu - tus es
 ca - tur: qui lo - cu - tus es cae - lum, et con - glo - ri - fi - ca - tur: qui lo - cu - tus es
 ca - tur: qui lo - cu - tus es cae - lum, et con - glo - ri - fi - ca - tur: qui lo - cu - tus es
 ca - tur: qui lo - cu - tus es cae - lum, et con - glo - ri - fi - ca - tur: qui lo - cu - tus es

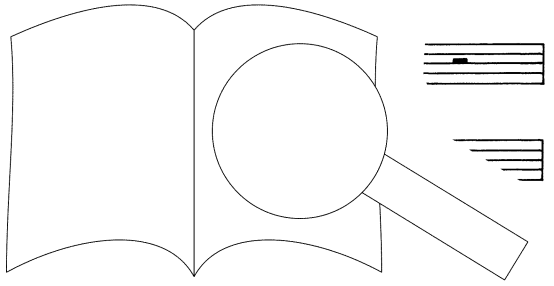

Et, san - ctam ca -
 Et, nam san - ctam ca -
 Bassi et u - nam san - ctam ca -
 et u - nam san - ctam ca -

tho - li - cam et a - Ec - cle - si - am. Con -
 tho - li - cam et li - cam Ec - cle - si - am. n -
 tho - li - cam po - sto - li - cam Ec - cle - si - am.
 tho - li - cam - po - sto - li - cam Ec - cle - si - am.

- num ba - ptis - ma in re - mis - si - o - ne - to -
 or u - num ba - ptis - ma in re - mis - si - ec - ca - to -
 fi - te - or u - num ba - ptis - ma in re - mis - si - ec - ca - to -
 fi - te - or u - num ba - ptis - ma in pec - ca - to -

rum. Et ex - spe - cto re - sur - mor - tu - o - rum.
 rum. Et ex - sp - e - nem mor - tu - o - rum.
 rum. Et - ti - o - nem mor - tu - o - rum.
 rum. sur - re - cti - o - nem mor - tu - o - rum.

(a) - e -
 e -
 e -
 Bassi e -
 Et, e -
 et -
 - tam
 - tam



ven - tu - ri sae - cu - li. A - men, a - men,
 ven - tu - ri sae - cu - li. A - men, a - men,
 vi - tam ven - tu - ri sae - cu - li. men, a - men,
 ven - tu - ri sae - cu - li. A - men, a - men,

a - men, a - men, a - men,
 a - men, a - men, men, a - men,
 a - men, a - men, a - men, a - men,
 a - men, a - men, a - men, a - men,

a - men, a - men,
 - men, a - men, a - men,
 - men, a - men, a - men,
 - men, a - men, a - men,

men, a - men, a - men,
 men, a - men, a - men,
 a - men, a - men, a - men,
 a - men, a - men, a - men,

men, a - men, a - men,
 1 a - men, a - men,
 1 a - men, a - men,
 men, a - men, a - men,

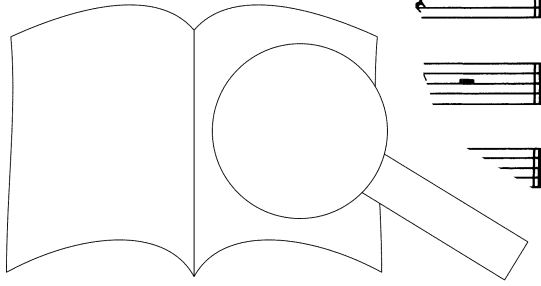

Sanctus

8. Sanctus

Adagio

San - ctus, San - ctus, ctus Do - mi - nus De - us Sa - ba - oth,
San - ctus, San - ctus Do - mi - nus De - us Sa - ba - oth,
San - ctus, San - ctus Do - mi - nus De - us Sa - ba - oth,
San - ctus, ctus, San - ctus Do - mi - nus De - us th,

De - us Sa - ba - oth, San - ctus Do - mi - nus De - us
De - us Sa - ba - oth, San - ctus Do - mi - nus De - us
De - us Sa - ba - oth, San - ctus Do - mi - nus De - us
De - us Sa - ba - oth, San - ctus Do - mi - nus De - us

Allegro

Ple - ni sunt coe - li et ter - ra glo - ri - a
Ple - ni sunt coe - li et ter - ra glo - ri - a
Ple - ni sunt coe - li et ter - ra glo - ri - a
Ple - ni sunt coe - li et ter - ra glo - ri - a

ri - a tu - ple - ni sunt
cu - a, ple - ni sunt
tu - a, ple - ni sunt
a tu - a, ple - ni sunt

coe - li et ter - - ra glo - ri - a tu
 coe - li et ter - - ra glo - ri - - O - san - na in ex -
 coe - li et ter - - ra glo a.
 coe - li et ter - - ra tu - a.

O - san - na in ex - cel
 cel - - sis, o -
 O - san - na in ex - - sis,
 O - san - na - - sis,

in ex - cel - - sis, in ex -
 na in ex - cel - in ex -
 sis, in ex - cel - in ex -
 o - san - na in ex - cel in ex -

cel - - sis, o - san - na in ex - cel ex - cel - sis, in ex -
 cel - - sis, in ex - cel sis, o - san - na in ex -
 cel - - sis in ex - cel - sis, o - san - na in ex -
 cel in ex - cel - sis,

sis, in ex - cel
 sis, in ex - cel
 sis, in ex - cel
 o - san - na in ex - cel - sis, in ex - cel

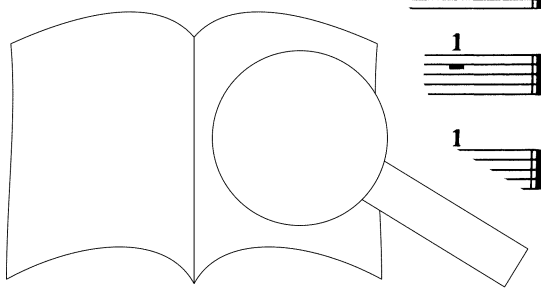

PROBEPARTITUR
 Ausgabqualität gegenüber Original evtl. gemindert • Evaluation Copy - Quality may be reduced • Carus-Verlag

Benedictus

9. Benedictus

Allegretto

33 Solo 35

Be - ne - di - ctus qui ve - nit
Be - ne - di - ctus qui ve - nit
Be - ne - di - ctus qui ve - nit
Be - ne - di - ctus qui

40

ae, in no - mi - ne Do - mi - ni.
no - mi - ne, in no - mi - ne Do - mi - ni.
in no - mi - ne, in no - mi - ne Do - mi - ni.
in no - mi - ne, in no - mi - ne Do - mi - ni.

4. 21

(no) - mi - ne Do - mi - ni.
Be - ne - di - ctus qui ve - nit in no - mi - ne Do - mi -
ne - di - ctus qui ve - nit in no - mi - ne Do - mi -
ne - di - ctus qui ve - nit in no - mi - ne Do - mi - ni.

76

mi - ne
mi
in no - mi - ne Do
ni, in no - mi - ne Do mi

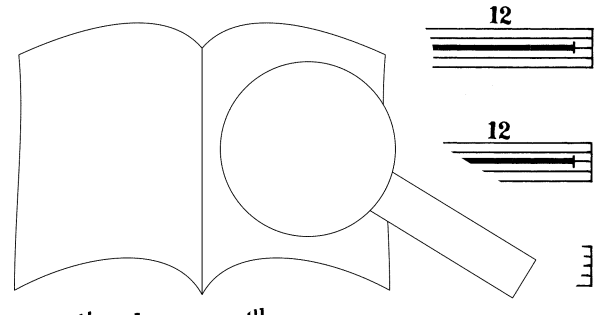

PROBENPARTITUR
Ausgabequalität gegenüber Original evtl. gemindert • Evaluation Copy - Quality may be reduced • Carus-Verlag

(bene)-di - ctus qui ve - nit, be - ne - di - ctus qui ve - nit no - mi - ne, in
 be - ne - di - ctus qui ve - nit in - no - mi - ne, in
 be - ne - di - ctus qui ve - nit in no - mi - ne, in
 Bassi qui ve - nit, be - ne - di - ctus qui ve in no - mi - ne, in

no - mi - ne Do mi - ni.
 no - mi - ne Do mi - ni.
 no - mi - ne Do mi - ni.
 no - mi - ne mi - ni.

be - ne - di - ctus qui ve - r - mi -
 mi - ni, qui ve - nit in te so - mi -
 be - ne - di - ctus qui ve - nit in no - mi - ne Do - mi -
 Do - mi - ni, be - ne - di - ctus qui ve - nit in no - mi - ne Do - mi -

ni, be - ne - di ctus ve - nit in no - mi - ne,
 ni, be - ne - di ctus qui ve - nit in no - mi - ne,
 ni, qui ve - nit in no - mi - ne,
 ni, qui ve - nit in no - mi - ne,

mi - ne
 mi - ne
 no - mi - ne
 in no - mi - ne mi - ni.

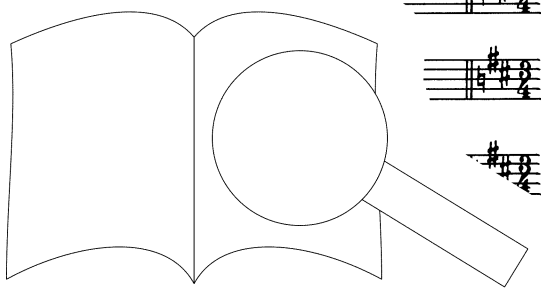

O - san - na in ex - cel - sis,

O - san - na in ex - cel - sis,

O - san - na in ex - cel - sis,

140

O - san - na in ex - cel - sis, in

san - na in

san - na in ex - cel - sis,

o - san - na in

144

cel - sis,

cel - sis,

ex - cel - sis,

cel

in ex - cel - sis,

in ex - cel - sis,

150

sis, o - san - na in ex - cel - sis, in ex -

sis, in ex - cel - sis, o - san - na in ex -

sis, in ex - cel - sis, o - san - na in ex -

sis, in ex - cel - sis,

155

sis, in ex - ce

sis, in ex - ce

sis, in ex - ce

o - san - na in ex - cel - sis, in ex - cel - sis.

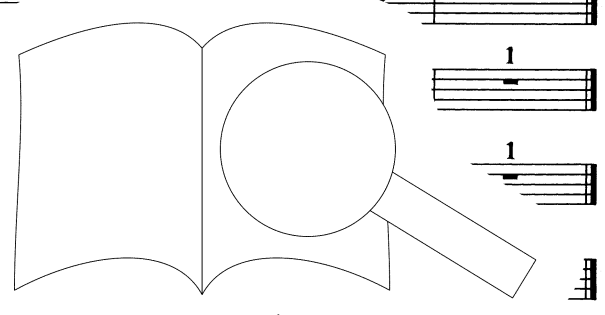

Agnus Dei

10. Agnus Dei

Adagio

40

41

11. Dona nobis pacem

Vivace

VI.1

Musical score for measures 40-43. It features four staves: Violin I, Violin II, Violin III, and Bass. The key signature is one sharp (F#) and the time signature is 3/4. Measure 40 contains whole rests for all parts. Measure 41 begins with a half note G4 in the Violin I part, followed by a half note G4 in the Violin II part, a half note G4 in the Violin III part, and a half note G4 in the Bass part. Measure 42 continues with a half note G4 in the Violin I part, a half note G4 in the Violin II part, a half note G4 in the Violin III part, and a half note G4 in the Bass part. Measure 43 continues with a half note G4 in the Violin I part, a half note G4 in the Violin II part, a half note G4 in the Violin III part, and a half note G4 in the Bass part.

Musical score for measures 44-47. It features four staves: Violin I, Violin II, Violin III, and Bass. The key signature is one sharp (F#) and the time signature is 3/4. Measure 44 contains a half note G4 in the Violin I part, a half note G4 in the Violin II part, a half note G4 in the Violin III part, and a half note G4 in the Bass part. Measure 45 contains a half note G4 in the Violin I part, a half note G4 in the Violin II part, a half note G4 in the Violin III part, and a half note G4 in the Bass part. Measure 46 contains a half note G4 in the Violin I part, a half note G4 in the Violin II part, a half note G4 in the Violin III part, and a half note G4 in the Bass part. Measure 47 contains a half note G4 in the Violin I part, a half note G4 in the Violin II part, a half note G4 in the Violin III part, and a half note G4 in the Bass part.

Musical score for measures 48-51. It features four staves: Violin I, Violin II, Violin III, and Bass. The key signature is one sharp (F#) and the time signature is 3/4. Measure 48 contains a half note G4 in the Violin I part, a half note G4 in the Violin II part, a half note G4 in the Violin III part, and a half note G4 in the Bass part. Measure 49 contains a half note G4 in the Violin I part, a half note G4 in the Violin II part, a half note G4 in the Violin III part, and a half note G4 in the Bass part. Measure 50 contains a half note G4 in the Violin I part, a half note G4 in the Violin II part, a half note G4 in the Violin III part, and a half note G4 in the Bass part. Measure 51 contains a half note G4 in the Violin I part, a half note G4 in the Violin II part, a half note G4 in the Violin III part, and a half note G4 in the Bass part.

Musical score for measures 52-55. It features four staves: Violin I, Violin II, Violin III, and Bass. The key signature is one sharp (F#) and the time signature is 3/4. Measure 52 contains a half note G4 in the Violin I part, a half note G4 in the Violin II part, a half note G4 in the Violin III part, and a half note G4 in the Bass part. Measure 53 contains a half note G4 in the Violin I part, a half note G4 in the Violin II part, a half note G4 in the Violin III part, and a half note G4 in the Bass part. Measure 54 contains a half note G4 in the Violin I part, a half note G4 in the Violin II part, a half note G4 in the Violin III part, and a half note G4 in the Bass part. Measure 55 contains a half note G4 in the Violin I part, a half note G4 in the Violin II part, a half note G4 in the Violin III part, and a half note G4 in the Bass part.

cem, pa - - cem. A i: do - na
 cem, pa - - cem. gnus De - i:
 pa - cem, pa - - cem. A - - gnus
 - - cem, pa - - cem. A -

no - bis, do - na, no - bis pa - -
 do - na, do - na, no - bis pa - -
 De - i: do - na no - bis pa
 - - do - na no - bis pa

cem, pa - - cem, pa
 cem, pa - - cem, pa
 - - cem pa
 cem, pa - - cem.

Do - na -
 - na - no - bis pa - - cem, pa -
 Do - -
 cem, do - - na - no - bis
 - - na - no - bis pa - - cem,

cem,
 cem, do - na no - bis
 pa - - cem, do - na no - bis p
 - - cem,

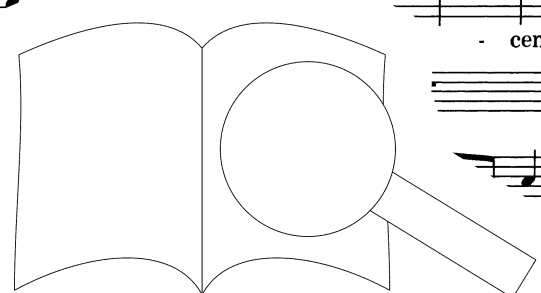

pa - cem, pa
do - na no - bis pa - cem, pa -
pa - cem, pa - cem, em, pa -
na - no-bis pa - cem, a no - bis pa -

cem,
cem,
cem,
cem,
no - bis pa - cem, pa -
do - na no - bis

do - na no - bis pa -
- cem, pa
do - na no - bis pa

cem,
pa
cem.
- cem.
- cem.
pa - - cem.
A - gnus
A -

no - bis, do - na, his
- i: do - na, do - ni
- gnus De - i: do - ni
A - - gnus De - i.
ao

PROBEPARTITUR
Ausgabequalität gegenüber Original evtl. gemindert • Evaluation Copy - Quality may be reduced • Carus-Verlag

pa - - - cem, pa - - - cem, cem,
 pa - - - cem, pa - - - cem,
 pa - - - cem, pa - - - cem,
 pa - - - cem, pa - - - cem,

100

f do - na no - bis *p* do - na no - bis pa - -
f do - na no cem, *p* do - na no - bis pa - -
f do - na cem, *p* do - na no - bis
 do - - - .s pa - - - cem, do - na

105

pa - - - cem, *pp* - - - na
 pa - - - cem, pa - - - cem, do - na
 em, pa - - - cem, do - na
 cem, pa - - - ce. - - - cem, do - na

110

no - bis, do - - - na no - bis cem, do - - - na
 no - bis, do - - - n' pa - - - cem, do - - - na
 no - bis, do - - - cem, do - - - na
 no - bis - bis pa - - - cem, do - - - na

114

- - - cem, pa - -
 pa - - - cem, pa - -
 - bis pa - - - cem, pa - -
 no - - - bis pa - - - cem, pa - - - cem,